



# **MEG Series**

## **Motherboard**

MEG X870E GODLIKE

User Guide

# Contents

Quick Start .....	4
Specifications .....	17
Special Features .....	23
Package Contents .....	24
Back Panel Connectors .....	25
5Gbps LAN Port LED Status Table .....	26
10Gbps LAN Port LED Status Table .....	26
Audio Jacks Connection .....	27
Installing Antenna .....	29
Overview of Components .....	30
CPU Socket .....	33
DDR5 DIMM Slots .....	35
PCI_E1~3: PCIe Expansion Slots .....	37
M2_1~5: M.2 Slots (Key M) .....	40
SATA_P3~P4 & SATA_S3~S4: SATA 6Gb/s Connectors .....	50
JAUD1: Front Audio Connector .....	50
JFP1, JFP2: Front Panel Connectors .....	51
CPU_PWR1~2, ATX_PWR1, PCIE_PWR1, PD_PWR1, JSATA_PWR1: Power Connectors .....	52
JBRG_HUB1: EZ Link Connector .....	54
JCI1: Chassis Intrusion Connector .....	55
JOCFS1: Safe Boot Jumper .....	55
JUSBC1~C2: USB Type-C® Front Panel Connectors .....	56
JUSB2~3: USB 5Gbps Connector .....	56
JUSB1 & JUSB_BRG_1: USB 2.0 Connector .....	57
CPU_FAN1, PUMP_SYS1~2, SYS_FAN1~7: Fan Connectors .....	58
JBAT1: Clear CMOS (Reset BIOS) Jumper .....	59
W_FLOW1: Water Flow Meter Connector .....	59
JLN1: Low Temperature Booting Jumper .....	60
T_SEN1~2: Thermal Sensor Connectors .....	60
JDASH1 : Tuning Controller connector .....	61
POWER1, RESET1: Power Button, Reset Button .....	61
V-Check Points Lite .....	62
M.2 XPANDER-Z SLIDER GEN5 card .....	63
BIOS_SW1: Multi-BIOS Switch .....	67

JDASH_SW1: Module Selector Switch .....	67
JRGB1: RGB LED connector .....	68
JARGB_V2_1~3: A-RAINBOW V2 (ARGB Gen2) LED connectors.....	69
JAF_2: EZ Conn-Header V2 .....	71
JPWRLED1: LED power input .....	73
LED_SW1: EZ LED Control .....	73
DYNAMIC DASHBOARD III.....	74
Installing OS, Drivers & MSI Center.....	81
Installing Drivers with MSI Driver Utility Installer.....	82
UEFI BIOS.....	85
BIOS Setup .....	86
Entering BIOS Setup .....	87
Resetting BIOS .....	88
Updating BIOS .....	88
Block Diagram .....	90
Regulatory Notices.....	i

# Quick Start

This Quick Start provides clear diagrams to help you install the motherboard. Video demonstrations are also available for some installations. Visit these videos by clicking the provided URL on your phone or tablet's web browser. Alternatively, you can scan the QR code to access the video directly.

## Preparing Tools and Components

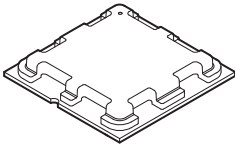

AMD® AM5 CPU

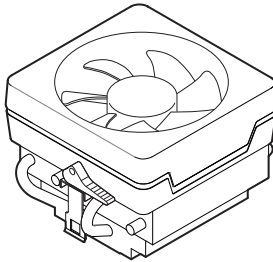

AM5 CPU Fan

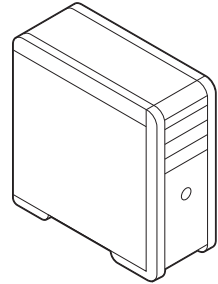

Chassis

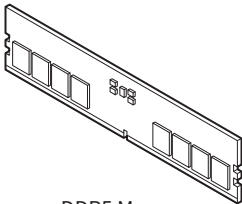

DDR5 Memory

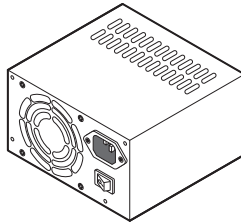

Power Supply Unit

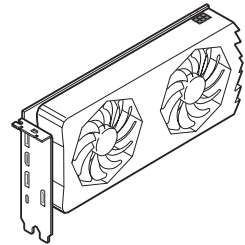

Graphics Card

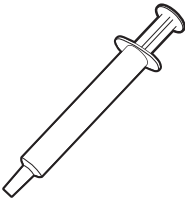

Thermal Paste

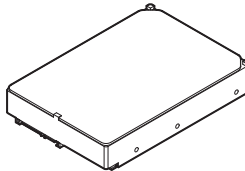

SATA Hard Disk Drive



A Package of Screws

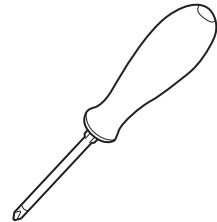

Phillips Screwdriver

## Safety Information

- The components included in this package are prone to damage from electrostatic discharge (ESD). Please adhere to the following instructions to ensure successful computer assembly.
- Ensure that all components are securely connected. Loose connections may cause the computer to not recognize a component or fail to start.
- Hold the motherboard by the edges to avoid touching sensitive components.
- It is recommended to wear an electrostatic discharge (ESD) wrist strap when handling the motherboard to prevent electrostatic damage. If an ESD wrist strap is not available, discharge yourself of static electricity by touching another metal object before handling the motherboard.
- Store the motherboard in an electrostatic shielding container or on an anti-static pad whenever the motherboard is not installed.
- Before turning on the computer, ensure that there are no loose screws or metal components on the motherboard or anywhere within the computer case.
- Do not boot the computer before installation is completed. This could cause permanent damage to the components as well as injury to the user.
- If you need help during any installation step, please consult a certified computer technician.
- Always turn off the power supply and unplug the power cord from the power outlet before installing or removing any computer component.
- Keep this user guide for future reference.
- Keep this motherboard away from humidity.
- Make sure that your electrical outlet provides the same voltage as is indicated on the PSU, before connecting the PSU to the electrical outlet.
- Place the power cord such a way that people can not step on it. Do not place anything over the power cord.
- All cautions and warnings on the motherboard should be noted.
- If any of the following situations arises, get the motherboard checked by service personnel:
  - Liquid has penetrated into the computer.
  - The motherboard has been exposed to moisture.
  - The motherboard does not work well or you can not get it work according to user guide.
  - The motherboard has been dropped and damaged.
  - The motherboard has obvious sign of breakage.
- Do not leave this motherboard in an environment above 60°C (140°F), it may damage the motherboard.

## Case stand-off notification

To prevent damage to the motherboard, any unnecessary mounting stand-off between the motherboard circuits and the computer case is prohibited. The Case standoff keep out zone signs will be marked on the backside of motherboard (as shown below) to serve as a warning to user.

## Avoid collision notification

Protective paint is printed around each screw hole to prevent parts from being scratched.

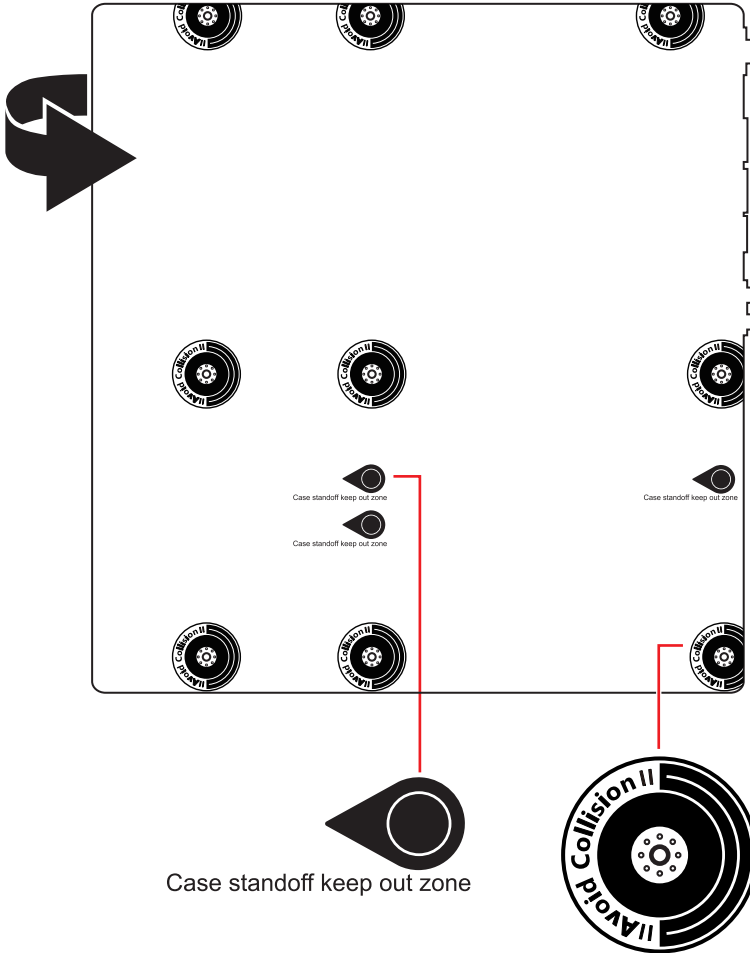

\* The illustration above is for reference only and may vary from the motherboard you purchased.

# Installing a Processor



• <https://msi.gm/SDBE5855>

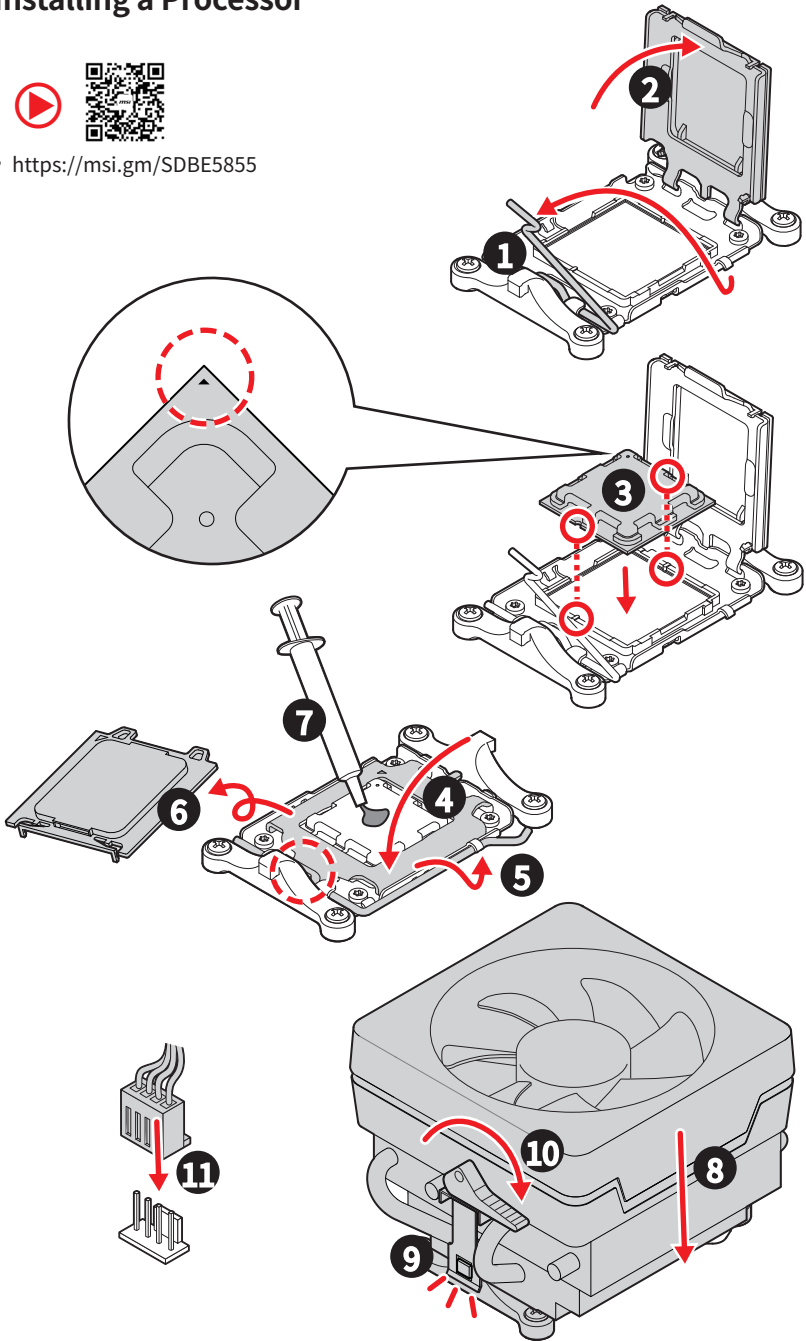

 **Important**

If you are installing the screw-type CPU heatsink, please follow the figure below to remove the retention module first and then install the heatsink.

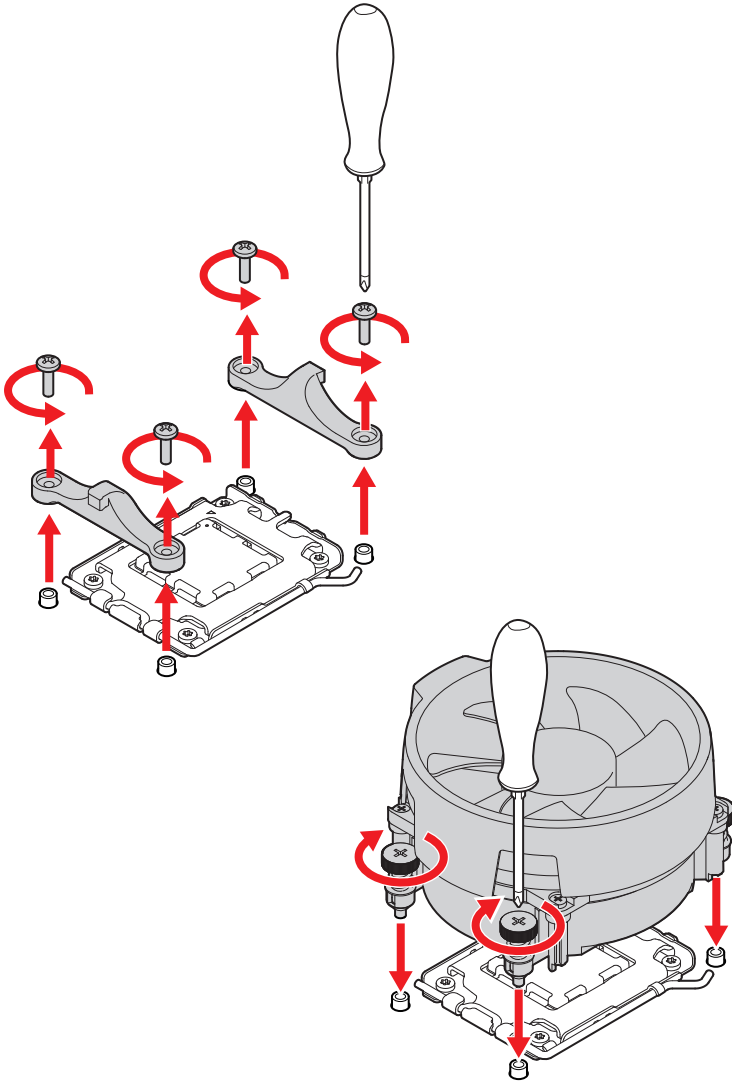

# Installing DDR5 memory



- <https://msi.gm/S647FF99>

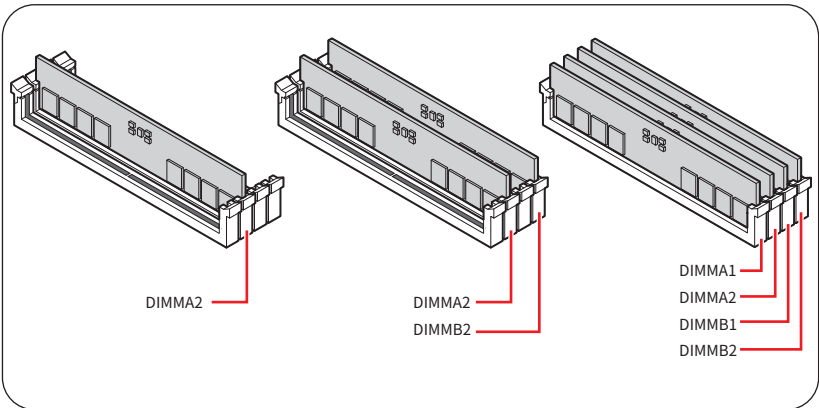
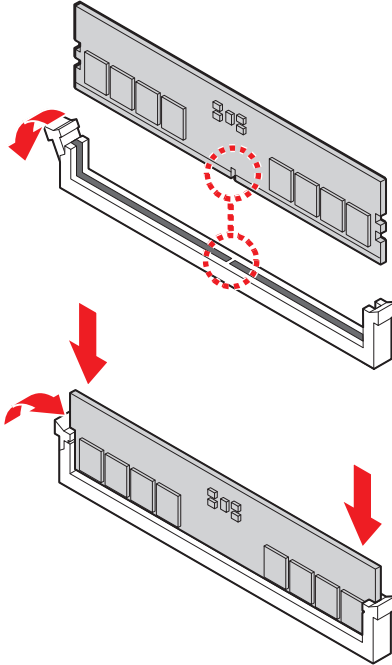

# Connecting the Front Panel Header



- <https://msi gm/S8EF7577>

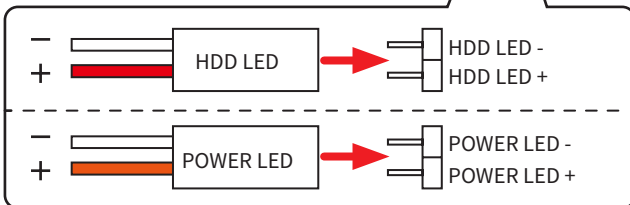
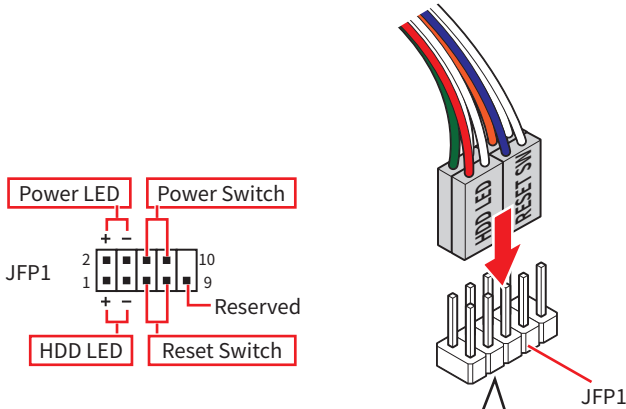
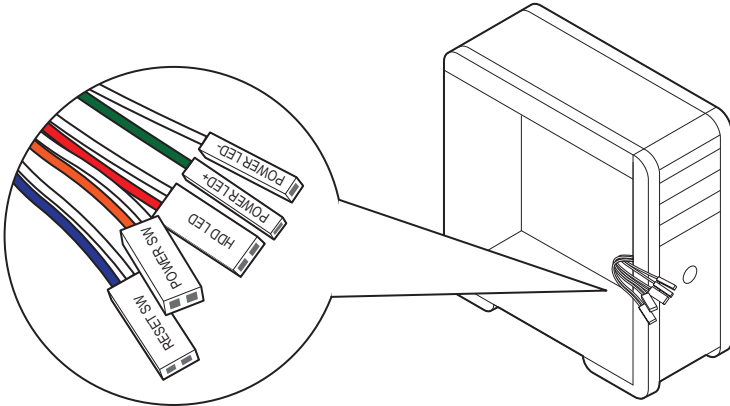

# Installing the Motherboard

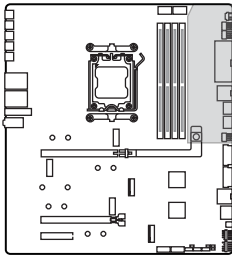

• <https://msi.com/S4BA9046>

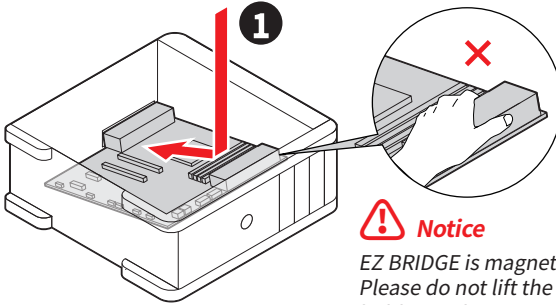

 **Notice**

*EZ BRIDGE is magnetically attached. Please do not lift the motherboard by holding only EZ BRIDGE.*

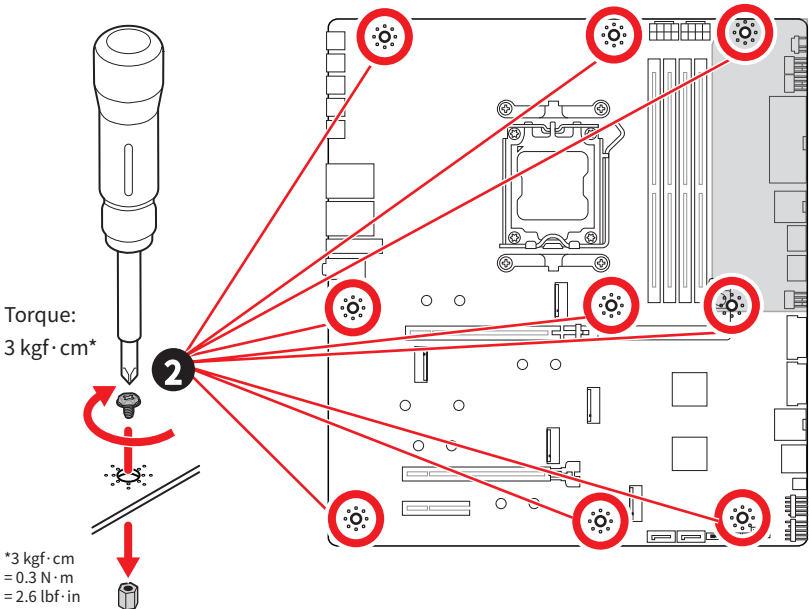

# Connecting the Power Connectors



- <https://msi.gm/SD937E2C>

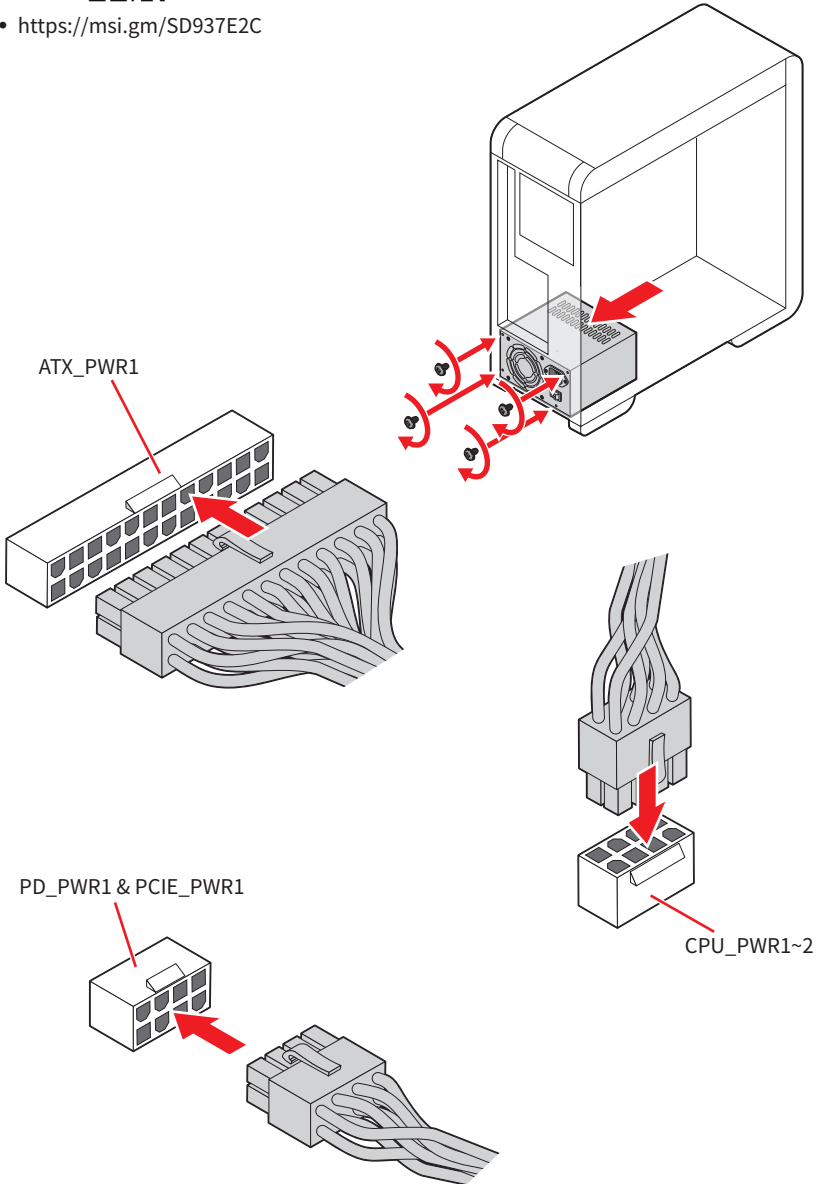

# Installing SATA Drives



• <https://msi.gm/S9369131>

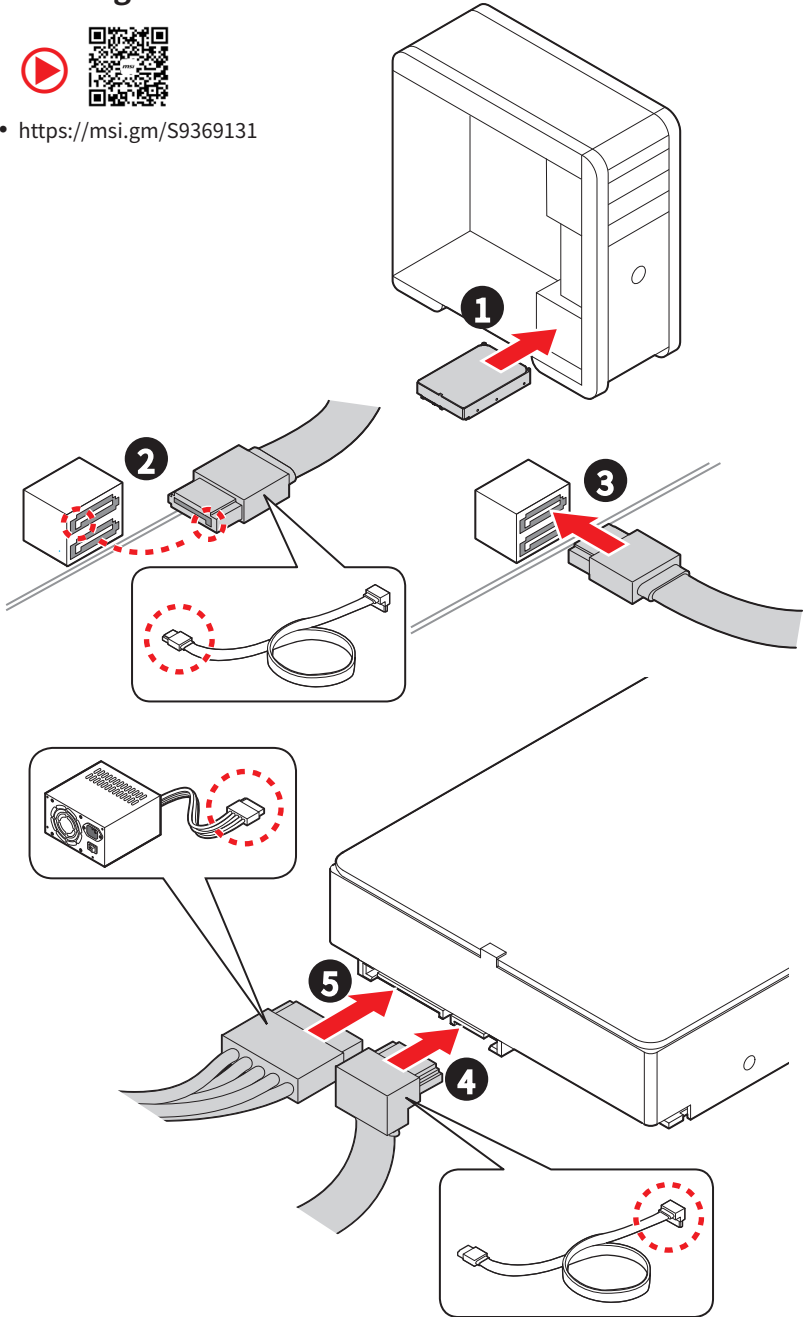

# Installing a Graphics Card



• <https://msi.gm/S6B36811>

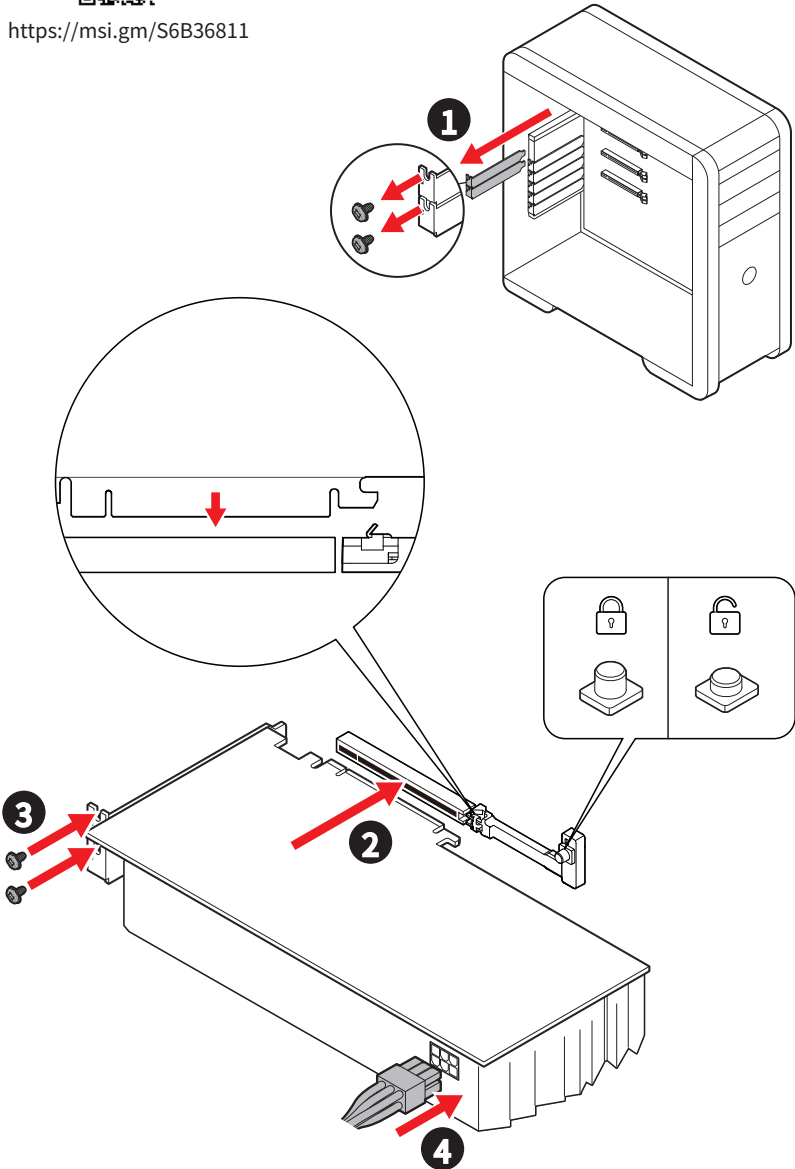

# Connecting Peripheral Devices

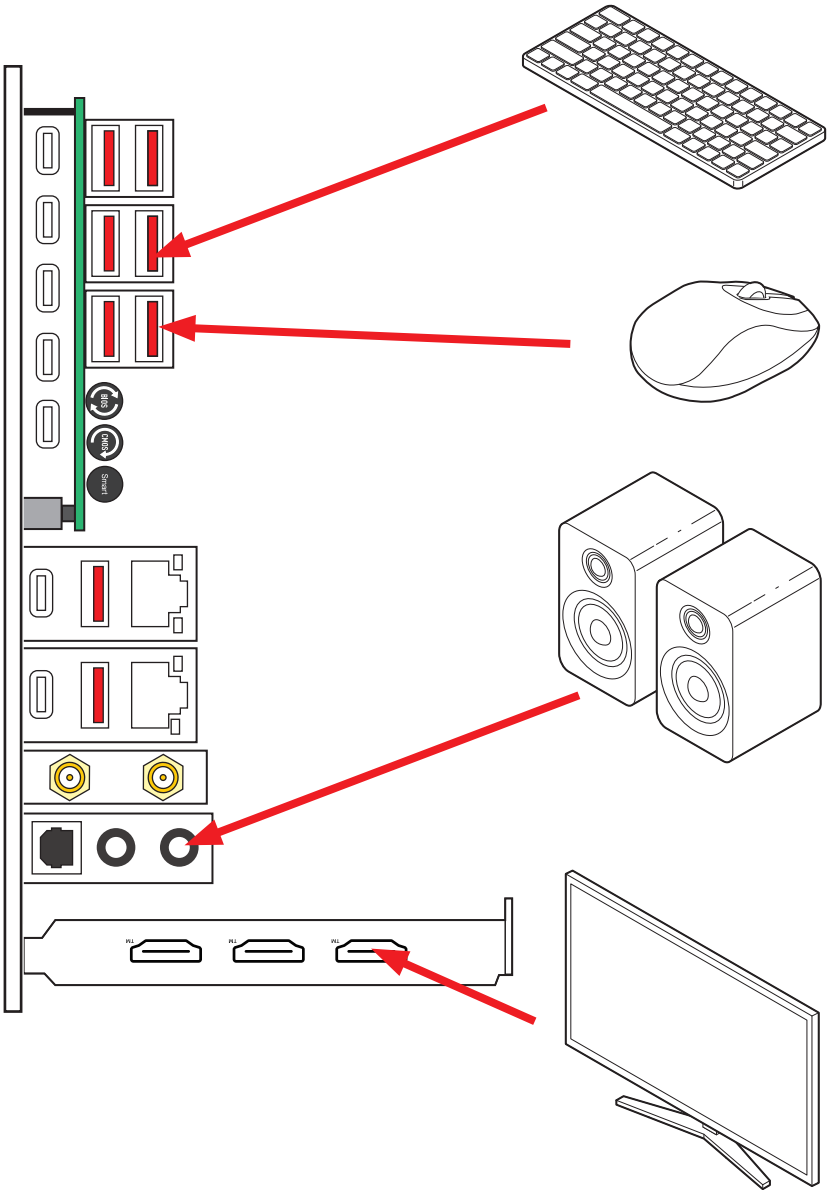

**Power On**

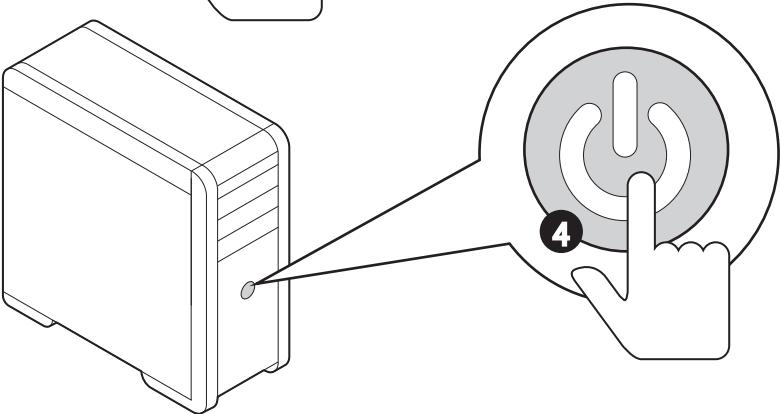
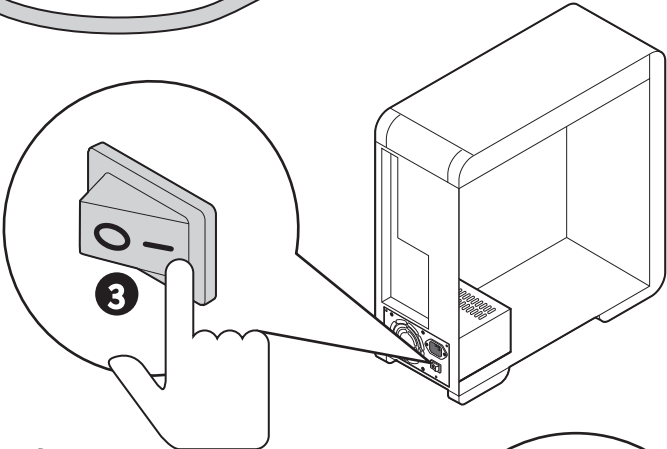
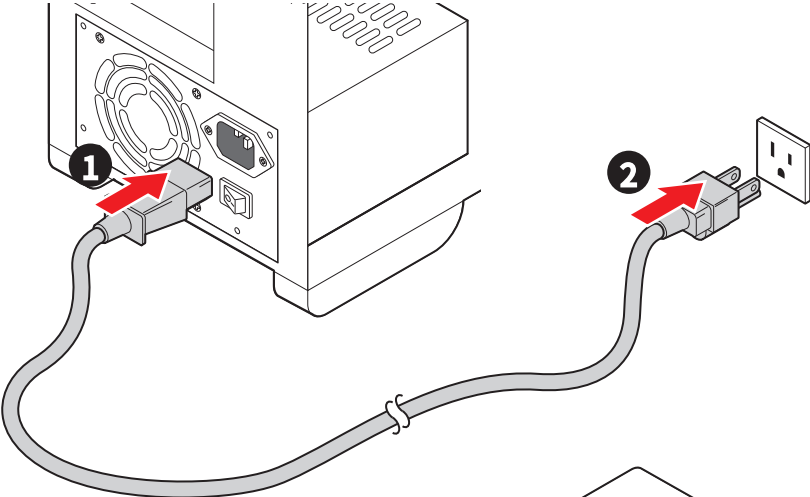

# Specifications

CPU	<ul style="list-style-type: none"> <li>• Supports AMD Ryzen™ 9000/ 8000/ 7000 Series Desktop Processors*</li> <li>• Processor socket AM5</li> </ul> <p>* Please go to <a href="http://www.msi.com">www.msi.com</a> to get the newest support status as new processors are released.</p>
Chipset	AMD X870E Chipset
Memory	<ul style="list-style-type: none"> <li>• 4x DDR5 memory slots*, supporting up to 256GB**</li> <li>• Supports AMD POR Speed and JEDEC Speed</li> <li>• Supports Memory Overclocking and AMD EXPO™</li> <li>• Supports Dual-Channel mode</li> <li>• Supports Non-ECC, Un-buffered memory</li> <li>• Supports CUDIMM, Clock Driver bypass mode only***</li> </ul> <p>* The DIMM slots on this motherboard only have single-sided latches.  ** Memory compatibility and supported speeds can vary depending on the CPU and memory configuration. For detailed information, please refer to the Memory Compatibility List available on the product's Support page or visit <a href="https://www.msi.com/support/">https://www.msi.com/support/</a>.  *** CUDIMM support and POR boot frequency may vary by CPU series, with manual overclocking available after boot. Certain CPUs may fail to boot, but future BIOS updates will improve compatibility.</p>
Expansion Slots	<ul style="list-style-type: none"> <li>• 2x PCIe x16 slots <ul style="list-style-type: none"> <li>• PCI_E1 &amp; PCI_E2 slots (From CPU) <ul style="list-style-type: none"> <li>• Supports up to PCIe 5.0 x16/ x0 or x8/ x8 (For Ryzen™ 9000/ 7000 Series processors)</li> <li>• Supports up to PCIe 4.0 x8/ x0 (For Ryzen™ 8700/ 8600/ 8400 Series processors)</li> <li>• Supports up to PCIe 4.0 x4/ x0 (For Ryzen™ 8500/ 8300 Series processors)</li> </ul> </li> </ul> </li> <li>• 1x PCIe x4 slot <ul style="list-style-type: none"> <li>• PCI_E3 slot* (From X870E chipset) <ul style="list-style-type: none"> <li>• Supports up to PCIe 4.0 x4</li> </ul> </li> </ul> </li> </ul> <p>* PCI_E3 &amp; M2_4 share the bandwidth. PCI_E3 will run at x2 speed when installing device in the M2_4 slot.</p>
Onboard Graphics	<ul style="list-style-type: none"> <li>• 2x USB4® ports, supporting DisplayPort 1.4 with HBR3 over USB Type-C® with a maximum resolution of 4K 60Hz*/**</li> </ul> <p>* Available only on processors featuring integrated graphics.  ** Graphics specifications may vary depending on the CPU installed.</p>
SATA Ports	<ul style="list-style-type: none"> <li>• 4x SATA 6Gb/s ports (From X870E chipset)</li> </ul>

Continued on next column

Continued from previous column

<b>M.2 SSD Slots</b>	<ul style="list-style-type: none"><li>• 5x M.2 slots (Key M)<ul style="list-style-type: none"><li>• M2_1 slot (From CPU)<ul style="list-style-type: none"><li>• Supports up to PCIe 5.0 x4 (For Ryzen™ 9000/ 7000 Series processors)</li><li>• Supports up to PCIe 4.0 x4 (For Ryzen™ 8000 Series processors)</li><li>• Supports 2260/ 2280 storage devices</li></ul></li><li>• M2_2 slots* (From CPU)<ul style="list-style-type: none"><li>• Supports up to PCIe 5.0 x4 (For Ryzen™ 9000/ 7000 Series processors)</li><li>• Supports up to PCIe 4.0 x4 (For Ryzen™ 8700/ 8600/ 8400 Series processors)</li><li>• Supports 2260/ 2280 storage devices</li></ul></li><li>• M2_3 slot (From X870E chipset)<ul style="list-style-type: none"><li>• Supports up to PCIe 4.0 x4</li><li>• Supports 2280/ 22110 storage devices</li></ul></li><li>• M2_4 slot (From X870E chipset)<ul style="list-style-type: none"><li>• Supports up to PCIe 4.0 x2</li><li>• Supports 2260/ 2280 storage devices</li></ul></li><li>• M2_5 slot (From X870E chipset)<ul style="list-style-type: none"><li>• Supports up to PCIe 4.0 x4</li><li>• Supports 2260/ 2280 storage devices</li></ul></li></ul></li><li>• M.2 XPANDER-Z SLIDER GEN5 card<ul style="list-style-type: none"><li>• 2x M.2 slots (Key M)</li><li>• Supports up to PCIe 5.0 x 4**</li><li>• Supports 2280 M.2 storage devices***</li></ul></li></ul> <p>* The M2_2 slot will be unavailable when using Ryzen™ 8500/ 8300 Series processors. ** The operating speed depends on the PCIe slot specification of motherboard. *** Only support the M.2 SSD as the data disk.</p>
<b>RAID</b>	<ul style="list-style-type: none"><li>• Supports RAID 0, RAID 1 and RAID 10 for SATA storage devices</li><li>• Supports RAID 0, RAID 1 and RAID 10 for M.2 NVMe storage devices</li></ul>
<b>Audio</b>	<p>Realtek® ALC4082 Codec + ES9219Q</p> <ul style="list-style-type: none"><li>• 7.1-Channel USB High Performance Audio</li><li>• Supports up to 32-bit/384kHz playback on front panel</li><li>• Supports S/PDIF output</li></ul>

Continued on next column

Continued from previous column

<b>LAN</b>	<ul style="list-style-type: none"> <li>• 1x Realtek® 8126 5Gbps LAN controller</li> <li>• 1x Marvell® AQC113CS 10Gbps LAN controller</li> </ul>
<b>Wi-Fi &amp; Bluetooth®</b>	<p>Wi-Fi 7</p> <ul style="list-style-type: none"> <li>• The Wireless module is pre-installed in the M.2 (Key-E) slot</li> <li>• Supports MU-MIMO TX/RX, 2.4GHz/ 5GHz/ 6GHz* (320MHz) up to 5.8Gbps</li> <li>• Supports 802.11 a/ b/ g/ n/ ac/ ax/ be</li> <li>• Supports Bluetooth® 5.4**, MLO, 4KQAM</li> </ul> <p>* 6GHz band support may depend on every country's regulations and Wi-Fi 7 will be ready in Windows 11 version 24H2.</p> <p>** The Bluetooth version may be updated, please refer to the Wi-Fi chipset vendor's website for details. Bluetooth 5.4 will be ready in Windows 11 version 24H2.</p>
<b>Power Connectors</b>	<ul style="list-style-type: none"> <li>• 1x 24-pin ATX main power connector</li> <li>• 2x 8-pin +12V power connectors</li> <li>• 1x 8-pin PCIe power connector</li> <li>• 1x 8-pin PD power connector*</li> </ul> <p>* To achieve USB PD 60W fast charging, the PD_PWR1 connector needs to be connected to the power supply unit.</p>
<b>Internal USB Connectors</b>	<ul style="list-style-type: none"> <li>• 1x USB 20Gbps Type-C® front panel port (From X870E chipset) <ul style="list-style-type: none"> <li>• Supports USB PD 60W fast charging*</li> </ul> </li> <li>• 1x USB 10Gbps Type-C® front panel port (From X870E chipset)</li> <li>• 2x USB 5Gbps connectors (From X870E chipset) <ul style="list-style-type: none"> <li>• Supports additional 4 USB 5Gbps ports</li> </ul> </li> <li>• 1x USB 2.0 connector (From X870E chipset) <ul style="list-style-type: none"> <li>• Supports additional 2 USB 2.0 ports</li> </ul> </li> </ul> <p>* To achieve USB PD 60W fast charging for JUSB2, the PD_PWR1 connector needs to be connected to the power supply unit.</p>
<b>Fan Connectors</b>	<ul style="list-style-type: none"> <li>• 1x 4-pin CPU fan connector</li> <li>• 2x 4-pin water-pump/ system fan connector</li> </ul>

Continued on next column

Continued from previous column

<b>EZ BRIDGE</b>	<ul style="list-style-type: none"><li>• 2x System panel connectors</li><li>• 2x 2-pin Thermal sensor connectors</li><li>• 1x Tuning controller connector</li><li>• 1x EZ Conn-Header V2 (JAF_2)</li><li>• 1x USB 2.0 Type-A connector (From Hub GL850G)<ul style="list-style-type: none"><li>• Supports additional 2 USB 2.0 ports</li></ul></li><li>• 1x 14-pin EZ Link connector</li><li>• 1x Power Button</li><li>• 1x Reset Button</li><li>• 1x EZ PCIe Release Button</li></ul>
<b>EZ CONTROL HUB</b>	<ul style="list-style-type: none"><li>• 1x 3-pin Water flow connector</li><li>• 7x 4-pin System fan connectors</li><li>• 1x 4-pin RGB LED connector</li><li>• 2x 3-pin A-RAINBOW V2 (ARGB Gen2) LED connectors</li><li>• 1x 14-pin EZ Link connector</li><li>• 1x SATA power connector</li></ul>
<b>System Connectors</b>	<ul style="list-style-type: none"><li>• 1x Front panel audio connector</li><li>• 1x Chassis Intrusion connector</li></ul>
<b>Jumpers</b>	<ul style="list-style-type: none"><li>• 1x Clear CMOS jumper</li><li>• 1x OC safe boot jumper</li></ul>
<b>LED Features</b>	<ul style="list-style-type: none"><li>• 1x 3-pin A-RAINBOW V2 (ARGB Gen2) LED connector</li><li>• 1x LED Demo connector</li></ul>

Continued on next column

Continued from previous column

<b>Back Panel Connectors &amp; Others</b>	<ul style="list-style-type: none"> <li>• 2x USB 10Gbps Type-A ports (From X870E chipset)</li> <li>• 4x USB 10Gbps Type-A ports (From RTS5420 chipset)</li> <li>• 2x USB 40Gbps Type-C ports * / ** (From ASM4242)             <ul style="list-style-type: none"> <li>• Supports DisplayPort over USB Type-C®</li> </ul> </li> <li>• 3x USB 10Gbps Type-C ports (From CPU)</li> <li>• 2x USB 10Gbps Type-C ports (From X870E chipset)</li> <li>• 2x USB 10Gbps Type-A ports (From X870E chipset)</li> <li>• 1x Flash BIOS button</li> <li>• 1x Clear CMOS button</li> <li>• 1x Smart button</li> <li>• 1x 10G LAN (RJ45) jack</li> <li>• 1x 5G LAN (RJ45) jack</li> <li>• 2x Wi-Fi Antenna connectors</li> <li>• 2x audio jacks</li> <li>• 1x Optical S/PDIF Out connector</li> </ul> <p>* USB 40Gbps Type-C ports on the back panel and M2_2 slot share PCIe 5.0 x4 bandwidth. Both run at PCIe 5.0 x2 when a device is installed in the M2_2 slot. You can switch M2_2 to PCIe 5.0 x4 in the BIOS, but this will disable the USB 40Gbps Type-C ports.</p> <p>** USB 40Gbps Type-C ports on the back panel only run PCIe 4.0 x2 when install Ryzen™ 8500/ 8300 Series processors.</p>
<b>I/O Controller</b>	NUVOTON NCT6687-R Controller Chip
<b>Hardware Monitor</b>	<ul style="list-style-type: none"> <li>• CPU/ System/ Chipset temperature detection</li> <li>• CPU/ System/ Pump fan speed detection</li> <li>• CPU/ System/ Pump fan speed control</li> </ul>
<b>Form Factor</b>	<ul style="list-style-type: none"> <li>• E-ATX Form Factor</li> <li>• 10.9 in. x 12 in. ( 277mm x 305 mm)</li> </ul>
<b>BIOS Features</b>	<ul style="list-style-type: none"> <li>• 2x 256 Mb flash</li> <li>• UEFI AMI BIOS</li> <li>• ACPI 6.5, SMBIOS 3.7</li> <li>• Multi-language</li> </ul>

Continued on next column

Continued from previous column

**Software**

- Drivers
- MSI Center
- Acrobat
- Adobe Creative Cloud
- AIDA64 Extreme - MSI Edition
- CPU-Z MSI GAMING
- MSI App Player(BlueStacks)
- Norton 360
- Voicemod

# Special Features

## MSI Center

- MSI AI Engine
- Game Highlights
- Cooling Wizard
- Mystic Light
- Ambient Link
- Frozr AI Cooling
- Hardware Monitoring
- Live Update
- MSI Companion
- System Diagnosis
- True Color
- User Scenario
- Super Charger +

## EZ DIY

- Frozr AI Cooling Magnetic M.2 Shield Frozr
- EZ M.2 Clip II
- EZ PCIe Release
- Smart Button
- Flash BIOS Button
- Clear CMOS Button
- Pre-installed I/O Shield
- Metal Backplate
- EZ Antenna
- EZ Front Panel Cable
- EZ Conn-Design
- PCI-E STEEL ARMOR II
- All Aluminum Design
- EZ LED
- EZ LED Control
- Dynamic Dashboard III

## Thermal Features

- All Aluminum Design
- Wavy Fin Design
- Cross Heat-pipe Design

- M.2 Shield Frozr (Double-sided design)
- MOSFET thermal pad
- Extra choke pad
- Fan headers (CPU+ PUMP+ SYSTEM)

## Performance

- Core Boost
- VRM Power Design (Vcore/SCO/MSIC)
- Dual CPU Power
- Memory Boost
- Memory Force
- Lightning Gen 5 PCI-E Slot
- Lightning Gen 5 PCI-E M.2
- Lightning Gen 4 PCI-E Slot
- Lightning Gen 4 PCI-E M.2
- Front USB Type-C
- USB with PD
- Supplemental PCIe Power Connector
- Server Grade PCB
- 2oz Copper thickened PCB

## Audio

- Audio Boost 5 HD

## RGB Support

- Mystic Light
- Mystic Light Extension (RGB)
- Mystic Light Extension (ARGB V2)
- Audio Boost 5 HD
- Ambient Devices Support

## BIOS

- Click BIOS X
- AI Boost
- Performance Preset

# Package Contents

Please check the contents of your motherboard package. It should contain:

## Board

- 1x Motherboard

## Documentation

- 1x Quick installation guide
- 1x European Union Regulatory Notices

## Application

- 1x USB drive

## Cables

- 4x SATA 6Gb/s cables
- 1x 1 to 2 RGB Extension Cable
- 1x ARGB Extension Cable
- 1x 1 to 3 ARGB Extension Cable
- 2x Thermistor Cables
- 1x EZ Front Panel Cable
- 1x 1 to 3 EZ Conn-Cable (V2)
- 1x EZ Link Cable
- 1x 1 to 2 SATA Power Cable
- 1x M.2 Xpander FAN Control Cable

## Accessories

- 1x EZ CONTROL HUB
- 1x M.2 XPANDER-Z SLIDER GEN5 card
- 1x EZ Wi-Fi Antenna
- 1x Gaming cable sticker
- 1x Hub Screw set
- 1x EZ M.2 Clip II Remover
- 1x 0.5mm thermal pad (For Xpander-Z Slider Gen 5 card)
- 1x 1.25mm thermal pad (For Xpander-Z Slider Gen 5 card)



## **Important**

- *There is an ISO file in the supplied USB drive. Please do not delete it accidentally. For more information on installing drivers, please refer to **Installing OS, Drivers & MSI Center** chapter.*
- *If any of the above items are damaged or missing, please contact your retailer.*

# Back Panel Connectors

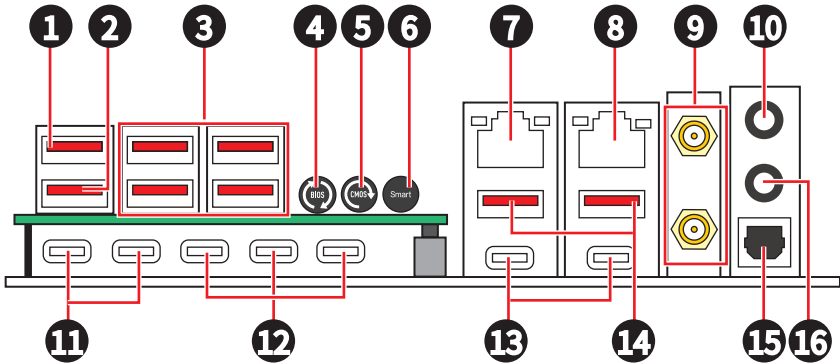

Item	Description
1	USB 10Gbps Type-A port (From X870E chipset) • Flash BIOS port
2	USB 10Gbps Type-A port (From X870E chipset)
3	USB 10Gbps Type-A ports (From RTS5420)
4	Flash BIOS button - Please refer to page 89 for details about updating BIOS with Flash BIOS button.
5	Clear CMOS button - Power off your computer. Press and hold the Clear CMOS button for about 5-10 seconds to reset BIOS to default values.
6	Smart button - there are 4 functions for the smart button. Please refer to the BIOS manual for details about selecting the smart button function. <ul style="list-style-type: none"> <li>• <b>Reset (default)</b> - press the smart button to reset the system.</li> <li>• <b>Mystic Light on/ off</b> - press the smart button to turn on/ off all the onboard LEDs. The Mystic Light on/ off function mode is unavailable when the LED_SW1 (EZ LED Control) switch turns OFF.</li> <li>• <b>Safe Boot</b> - press and hold the smart button while simultaneously starting the system to enter Safe Boot mode. This will boot the system with default settings and lower the PCIe mode associated with the CPU.</li> <li>• <b>Turbo Fan</b> - pressing the smart button synchronizes the fan speed of all fans. The fan speed can be synchronized to full speed or default speed.</li> </ul>
7	10Gbps LAN port
8	5Gbps LAN port
9	Wi-Fi Antenna connectors
10	Line-out jack

Item	Description
11	USB 40Gbps Type-C ports (From ASM4242) <ul style="list-style-type: none"> <li>• Supports DisplayPort over USB Type-C®</li> </ul> * USB 40Gbps Type-C ports on the back panel and M2_2 slot share PCIe 5.0 x4 bandwidth. Both run at PCIe 5.0 x2 when a device is installed in the M2_2 slot. You can switch M2_2 to PCIe 5.0 x4 in the BIOS, but this will disable the USB 40Gbps Type-C ports. ** USB 40Gbps Type-C ports on the back panel only run PCIe 4.0 x2 when install Ryzen™ 8500/ 8300 Series processors.
12	USB 10Gbps Type-C port (From CPU)
13	USB 10Gbps Type-C port (From X870E chipset)
14	USB 10Gbps Type-A port (From X870E chipset)
15	Optical S/PDIF Out connector
16	Mic-in jack

## 5Gbps LAN Port LED Status Table

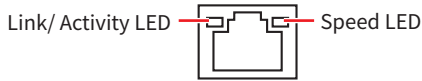

Link/ Activity LED		Speed LED	
Status	Description	Status	Speed
Off	No link	Off	10 Mbps
Yellow blinking slowly	Linked	Green	100 Mbps/ 1 Gbps/ 2.5 Gbps
Yellow blinking rapidly	Data activity	Orange	5 Gbps

## 10Gbps LAN Port LED Status Table

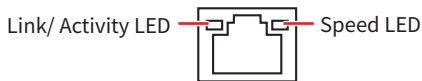

Link/ Activity LED		Speed LED	
Status	Description	Status	Speed
Off	No link	Off	—
Green blinking slowly	Linked	Green	100 Mbps/ 1 Gbps/ 2.5 Gbps/ 5Gbps
Green blinking rapidly	Data activity	Yellow	10 Gbps

# Audio Jacks Connection

## Audio jacks to headphone and microphone diagram

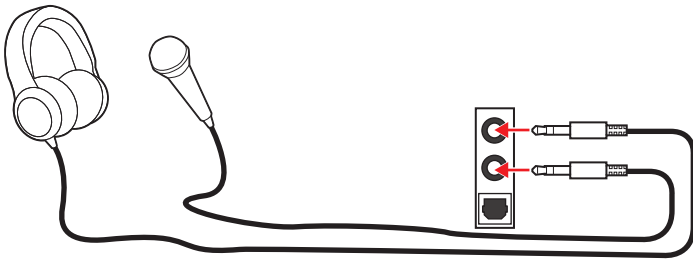

## Audio jacks to stereo speakers diagram

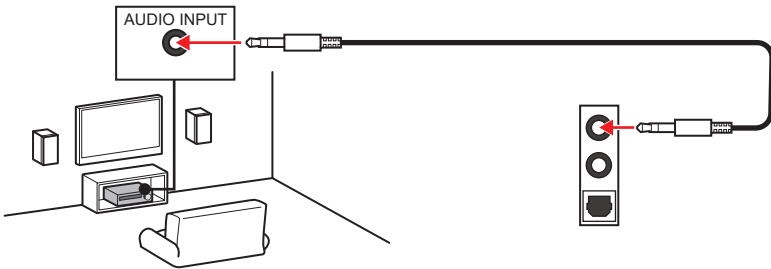

### Audio jacks to 4-channel speakers diagram

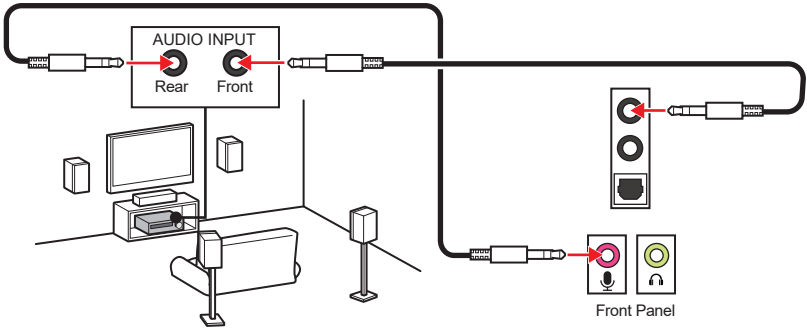

### Audio jacks to 5.1-channel speakers diagram

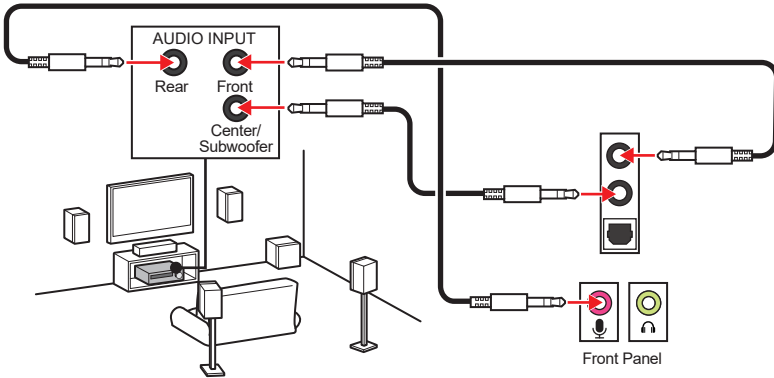

### Audio jacks to 7.1-channel speakers diagram

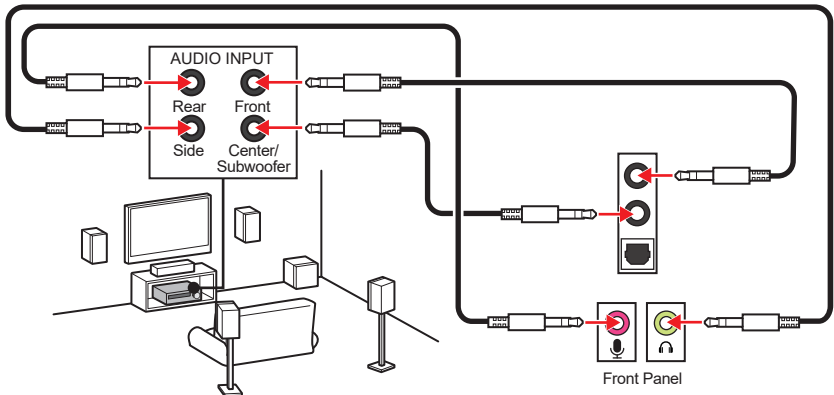

## Installing Antenna

1. Combine the antenna with the base.
2. Plug two antenna cables tight to the WiFi antenna connectors as shown.

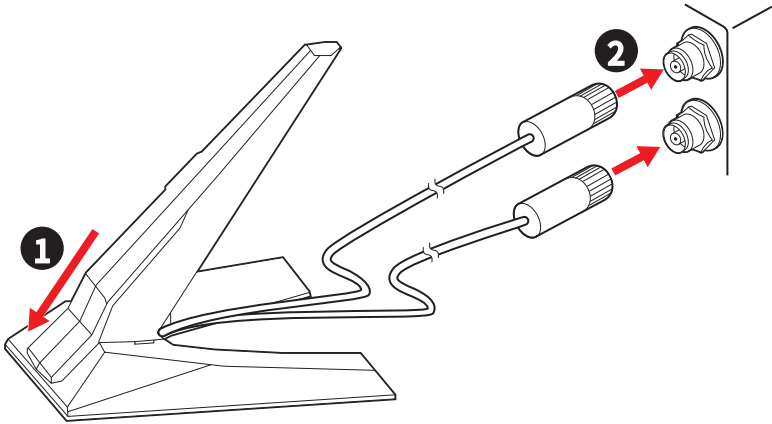

3. Place the antenna as high as possible for a better signal.

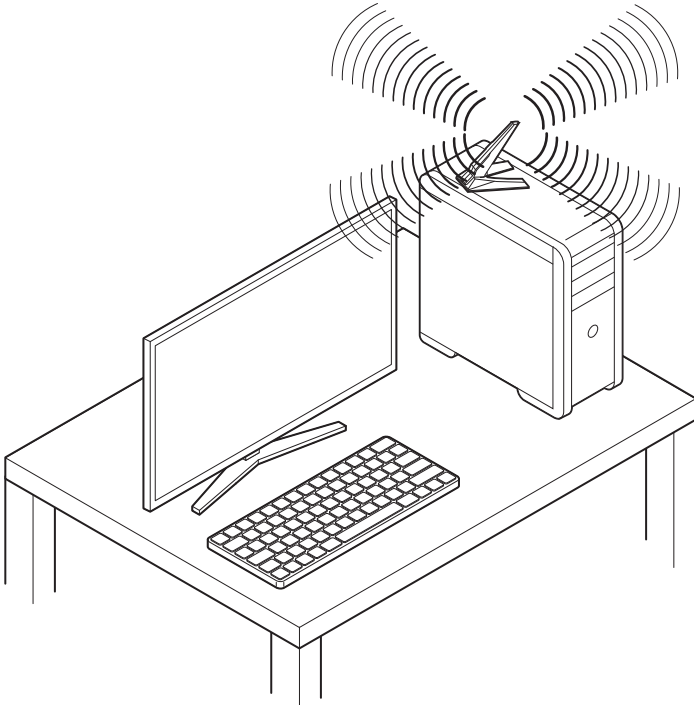

# Overview of Components

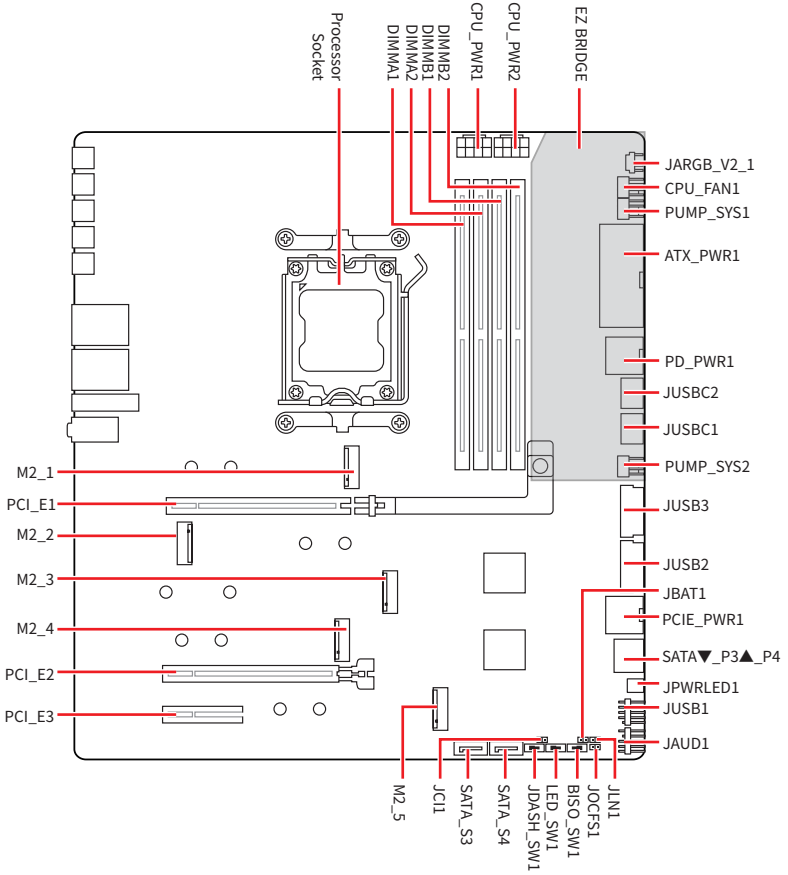

## EZ BRIDGE

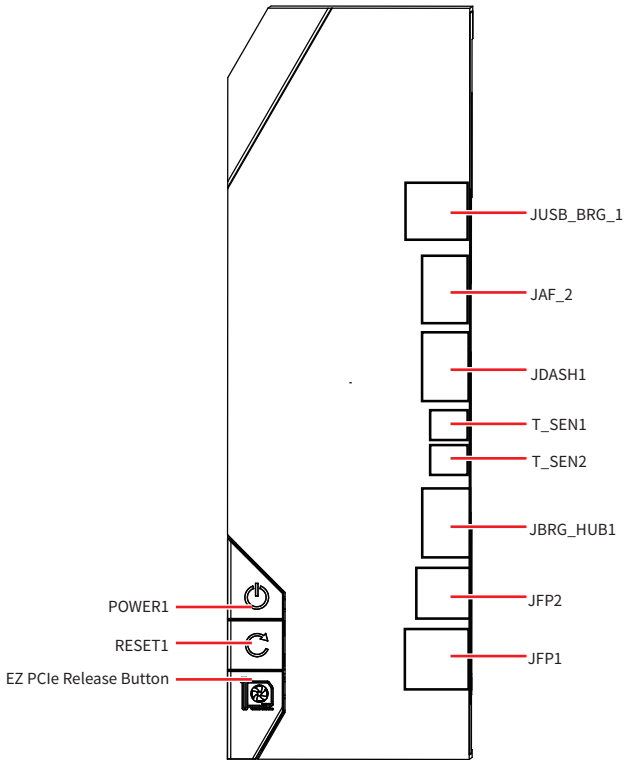

### **Important**

*EZ BRIDGE does not support hot-swapping. Do not unplug the connection while it is powered on.*

# EZ CONTROL HUB

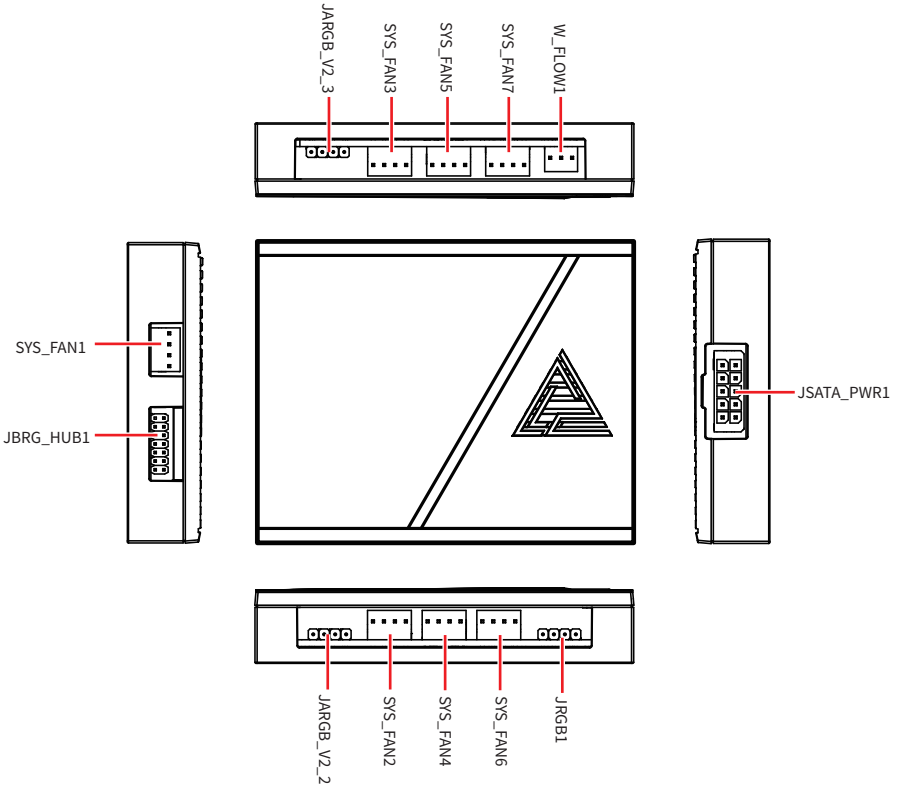

# CPU Socket

The AM5 socket is a modern CPU socket designed for AMD processors. It is a key component in contemporary computing systems, providing the foundation for powerful and efficient CPUs.

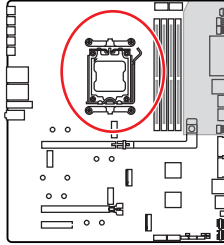

## Installing the CPU to the AM5 socket

The surface of the AM5 CPU has **two notches** and a **golden triangle** to assist in correctly lining up the CPU for motherboard placement. The golden triangle is the Pin 1 indicator.

To install the CPU, align the two notches on the AM5 socket with the two corresponding notches on the CPU. Please ensure that the gold triangle on the CPU serves as the PIN 1 indicator during the installation process.

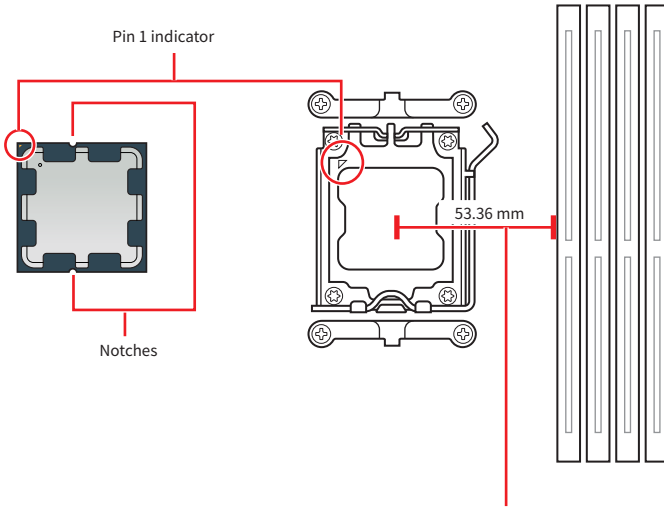

Distance from the center of the CPU socket to the nearest DIMM slot.

 **Important**

- *When changing the processor, the system configuration could be cleared and reset BIOS to default values, due to the AM5 processor's architecture.*
- *Please ensure that the motherboard and power supply are turned off and always disconnect the power cord from the power outlet before installing or removing the CPU.*
- *Please retain the CPU protective cap after installing the processor. MSI will deal with Return Merchandise Authorization (RMA) requests if only the motherboard comes with the protective cap on the CPU socket.*
- *Whenever the CPU is not installed, always protect the CPU socket pins by covering the socket with the protective cap.*
- *The CPU should only fit in one orientation, so do not force it. Gently place the CPU into the socket without applying excessive pressure.*
- *Please handle the CPU by the edges only; avoid touching the pins or the surface of the CPU. Any damage to the pins can result in a malfunctioning CPU.*
- *When installing a CPU, always remember to install a CPU heatsink. A CPU heatsink is necessary to prevent overheating and maintain system stability.*
- *Please install the CPU cooler according to the manufacturer's instructions. Make sure it is securely a tight seal with the CPU and attached to the motherboard to ensure proper heat dissipation.*
- *Overheating can seriously damage the CPU and motherboard. Always make sure the cooling fans work properly to protect the CPU from overheating. Be sure to apply an even layer of thermal paste (or thermal tape) between the CPU and the heatsink to enhance heat dissipation.*
- *This motherboard is designed to support overclocking. Before attempting to overclock, please make sure that all other system components can tolerate overclocking. Any attempt to operate beyond product specifications is not recommended. MSI® does not guarantee the damages or risks caused by inadequate operation beyond product specifications.*

# DDR5 DIMM Slots

The DDR5 DIMM slot is a dedicated connector designed to accommodate DDR5 (Double Data Rate 5) memory modules. It represents the latest standard in computer memory, providing enhanced data transfer speeds and efficiency.

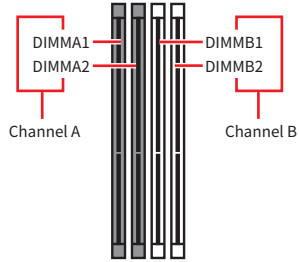
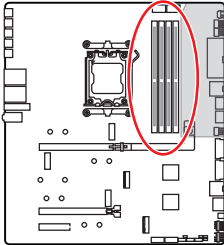

## Memory module installation recommendation

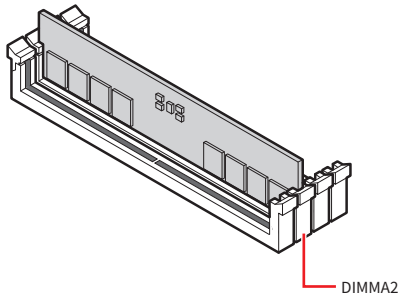

 **Important**

Always insert memory modules in the **DIMMA2** slot first.

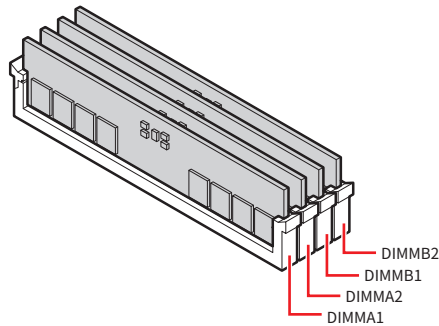
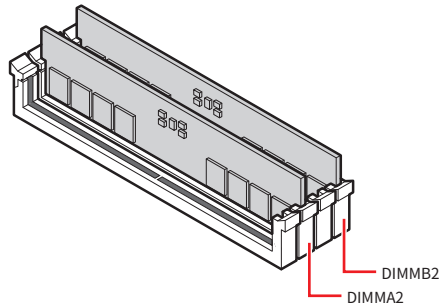

### Important

- The DIMM slots on this motherboard only have a single latch. Please be careful when installing or removing memory modules to avoid damaging the slots.
- Align the notch on the DDR5 module with the notch on the memory slot to ensure proper orientation. Do not force the module into the slot; it should slide in easily if properly aligned.
- To ensure system stability for Dual channel mode, memory modules must be of the same type, number and density.
- Some memory modules may operate at a lower frequency than the marked value when overclocking due to the memory frequency operates dependent on its Serial Presence Detect (SPD). Go to BIOS and find the **DRAM Speed** to set the memory frequency if you want to operate the memory at the marked or at a higher frequency.
- It is recommended to use a more efficient memory cooling system for full DIMMs installation or overclocking.
- The stability and compatibility of installed memory module depend on installed CPU and devices when overclocking.
- Please refer to [www.msi.com](http://www.msi.com) for more information on compatible memory.

## PCI\_E1~3: PCIe Expansion Slots

PCI Express (PCIe) expansion slots are used to connect add-on cards to the motherboard. These cards can provide additional functionality to your computer, such as graphics, networking, or storage.

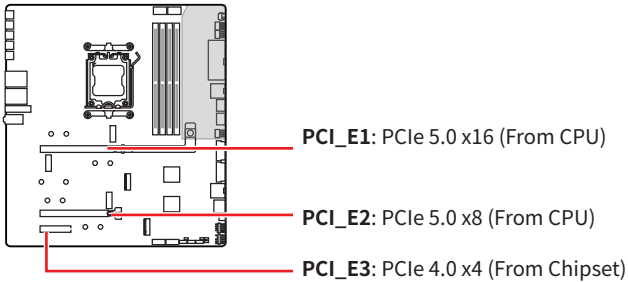

### **Important**

- If you install a large and heavy graphics card, you need to use a tool such as **MSI Graphics Card Bolster** to support its weight to prevent deformation of the slot.
- For a single PCIe x16 expansion card installation with optimum performance, using the **PCI\_E1** slot is recommended.
- When adding or removing expansion cards, always turn off the power supply and unplug the power supply power cable from the power outlet. Read the expansion card's documentation to check for any necessary additional hardware or software changes.
- **PCI\_E3** & **M2\_4** share the bandwidth. **PCI\_E3** will run at x2 speed when installing device in the **M2\_4** slot.

## Installing a graphics card into PCI\_E1 slot

1. Ensure that the EZ PCIe Release Button is in the **locked** position. If it is unlocked, press the button to lock it.
2. Insert the graphics card into the PCIe slot.

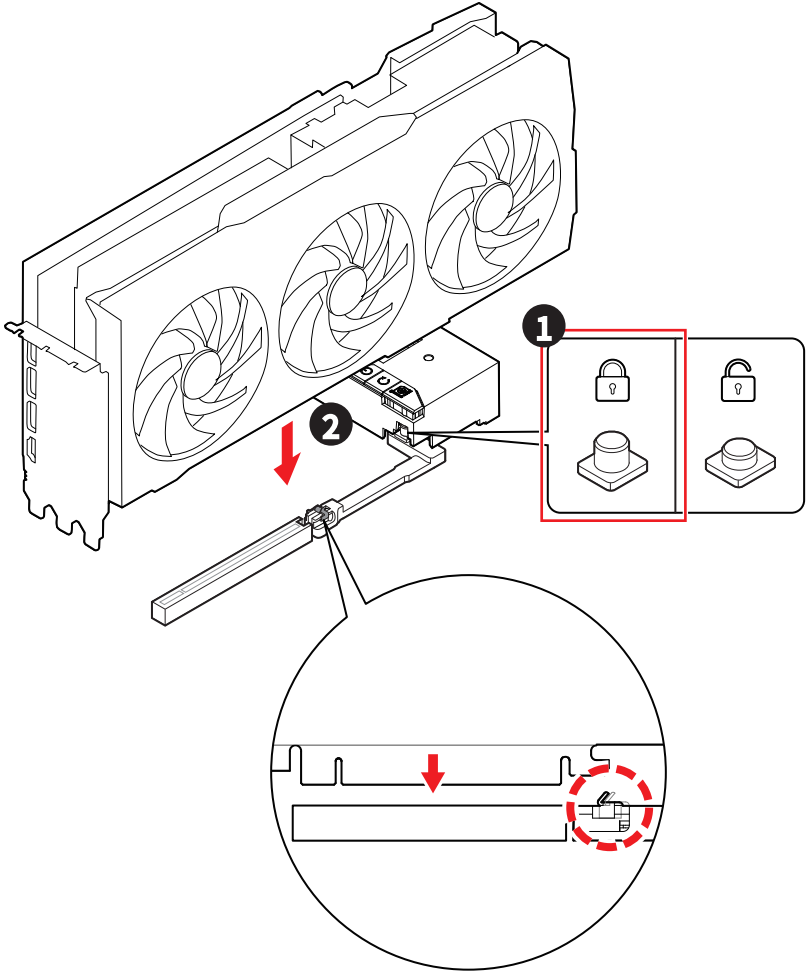

## Removing a graphics card from PCI\_E1 slot

1. Ensure that the EZ PCIe Release Button is in the **unlocked** position. If it is locked, press the button to unlock it.
2. Gently pull the graphics card out of the PCIe slot.

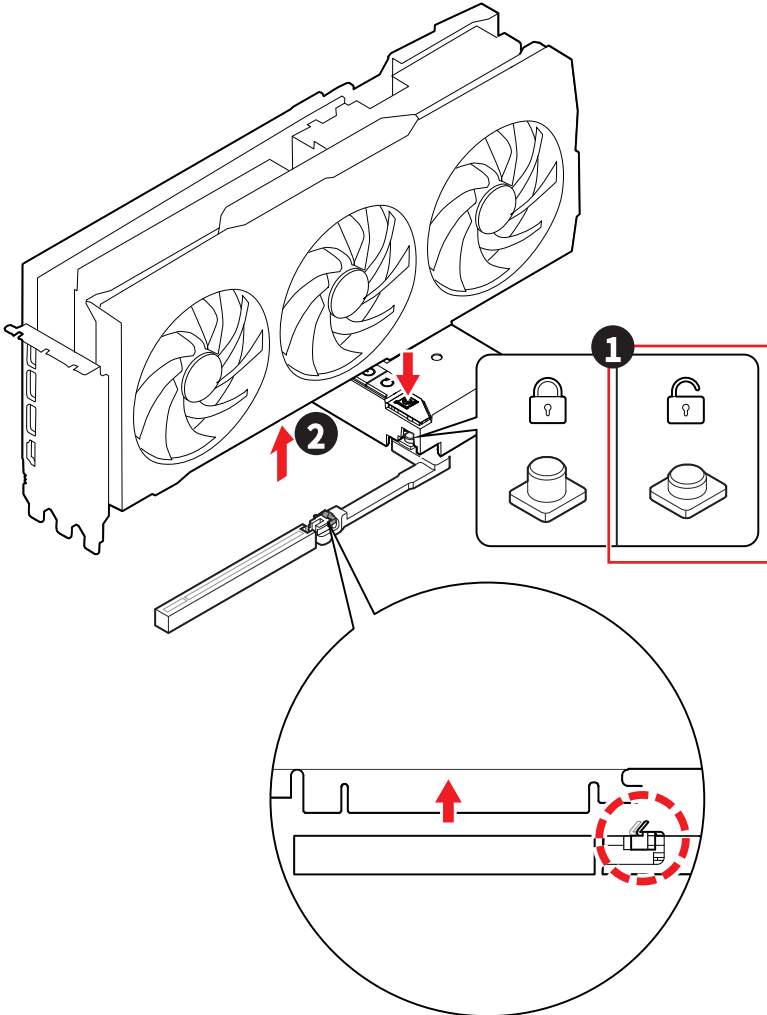

## M2\_1~5: M.2 Slots (Key M)

The M.2 slot is a small, high-speed expansion slot on a motherboard. It can be used to connect an M.2 SSD, which is a type of solid-state drive that offers faster performance than traditional SATA SSDs.

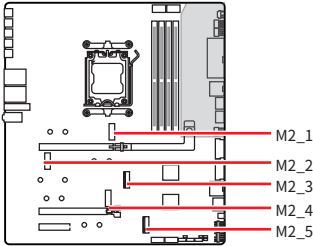

Watch the video to learn how to Install M.2 SSD with Screwless M.2 Shield Frozr heatsink.



• <https://msi.gm/S7F5D000>

### Important

If your M.2 SSD equips its own heatsink, please note the following:

- Remove the M.2 plate or rubber cube in the M.2 slot before installing M.2 SSD. Do not re-install the heatsink supplied with the motherboard.
- Ensure that the M.2 SSD heatsink you use fits the size limits to prevent damage.

### M.2 SSD Heatsink Size Restrictions

If you need to purchase an additional heatsink, please refer to the diagram below to confirm the M.2 installation space dimensions. Please also consider the height of the installed PCIe expansion card when determining M.2 installation space.

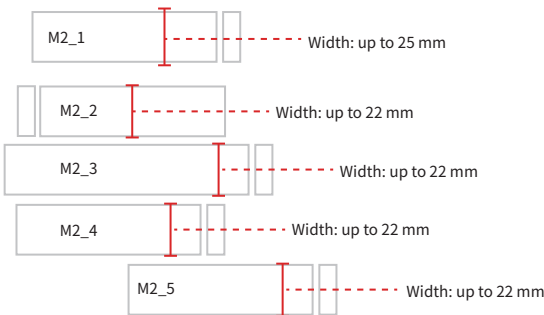

## Installing M.2 module into M2\_1 slot

1. Press and hold the end button of Screwless M.2 Shield Frozr heatsink.

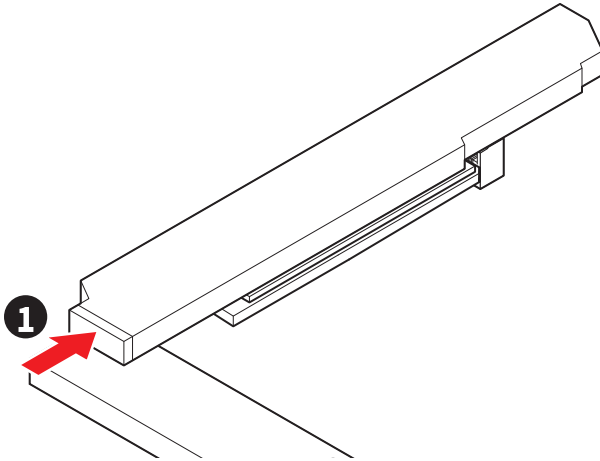

2. Slightly lift up the end part of Screwless M.2 Shield Frozr heatsink and move it forward to uninstall the heatsink.

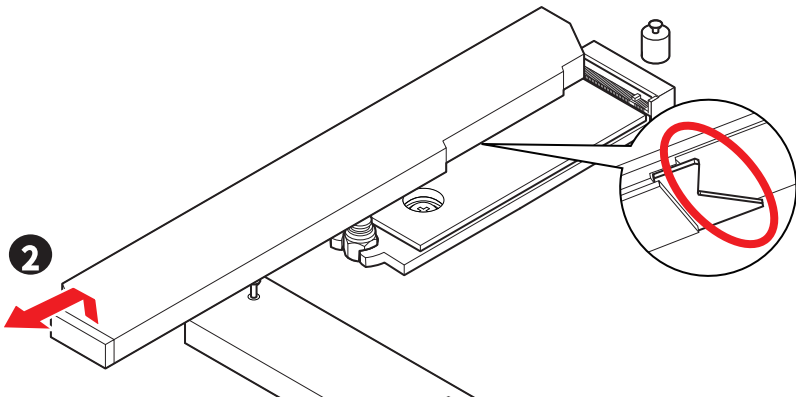

3. Remove the protective film from the M.2 thermal pads on the M.2 plate.

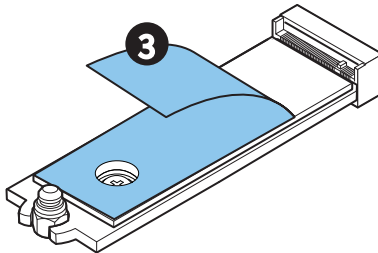

4. If you install 2260 SSD, exchange the **EZ M.2 Clip II** and the plate screw. Please note that you have to use the **EZ M.2 Chip II Remover** to remove and install the **EZ M.2 Clip II**. Skip this step if you install 2280 SSD.

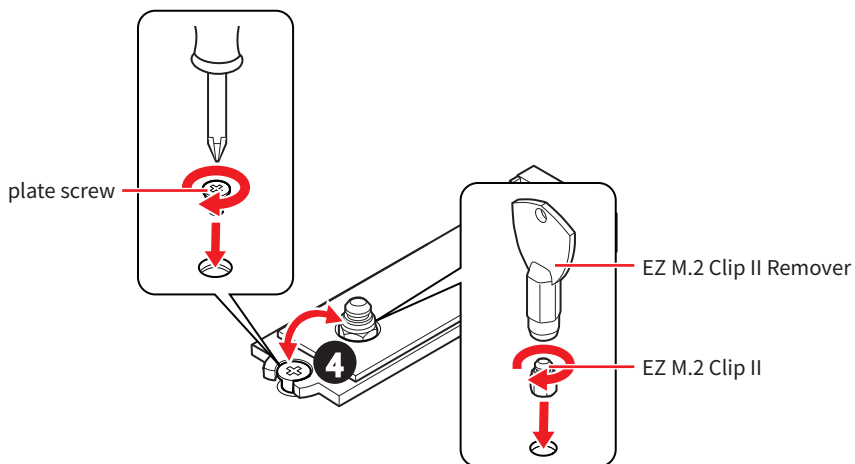

5. Insert your M.2 SSD into the M.2 slot at a 30-degree angle.
6. Use the EZ M.2 Clip II to lock and secure the SSD.

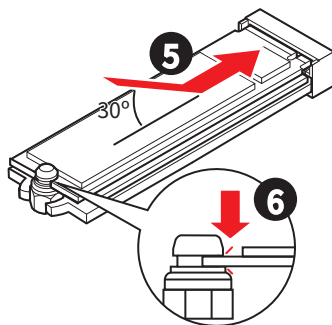

7. Remove the protective films from the thermal pads under Screwless M.2 Shield Frozr heatsink.
8. Align the notches under Screwless M.2 Shield Frozr heatsink with the tenons, and then put the heatsink back in place.
9. Press the end side of Screwless M.2 Shield Frozr heatsink to lock it completely.

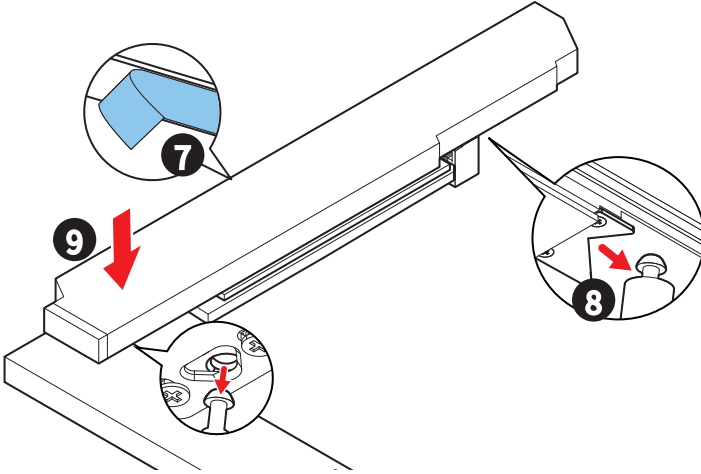

## Installing M.2 module into M2\_2/ M2\_3/ M2\_4 slot

1. Press and hold the end button of Screwless M.2 Shield Frozr heatsink.

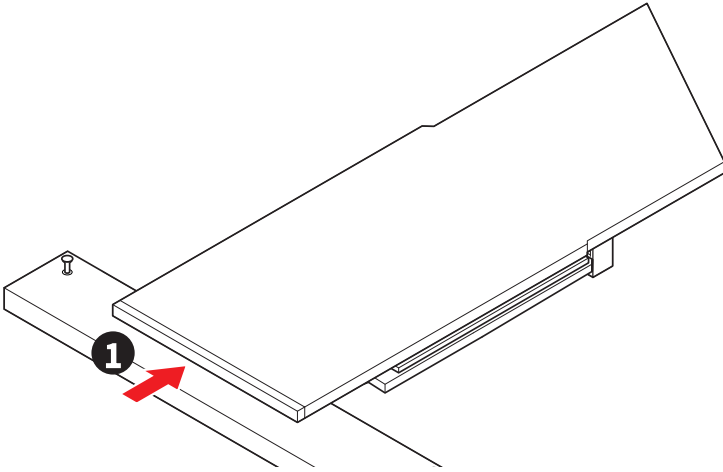

2. Slightly lift up the end part of Screwless M.2 Shield Frozr heatsink and move it forward to uninstall the heatsink.

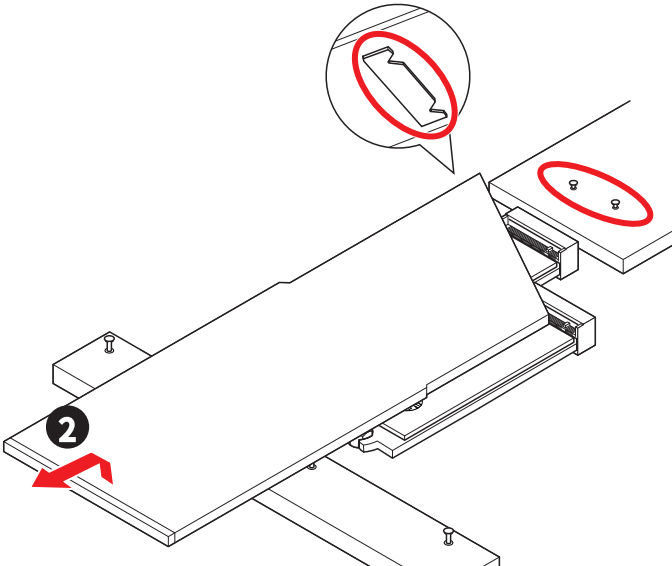

3. Remove the protective film from the M.2 thermal pads on the M.2 plate.

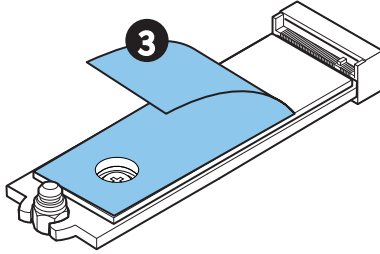

4. If you install 2260/ 22110 SSD, exchange the **EZ M.2 Clip II** and the plate screw. Please note that you have to use the **EZ M.2 Chip II Remover** to remove and install the **EZ M.2 Clip II**. Skip this step if you install 2280 SSD.

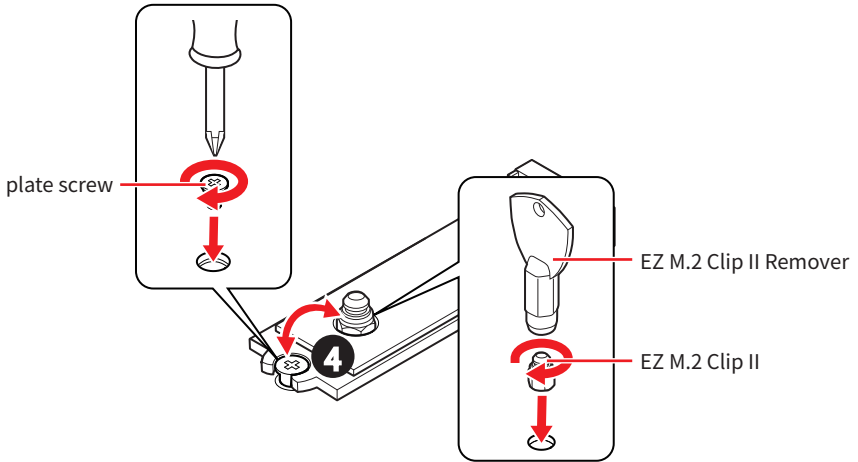

5. Insert your M.2 SSD into the M.2 slot at a 30-degree angle.
6. Use the EZ M.2 Clip II to lock and secure the SSD.

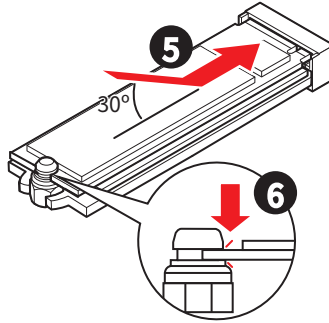

7. Remove the protective films from the thermal pads under Screwless M.2 Shield Frozr heatsink.
8. Align the notches under Screwless M.2 Shield Frozr heatsink with the tenons, and then put the heatsink back in place.
9. Press the end side of Screwless M.2 Shield Frozr heatsink to lock it completely.

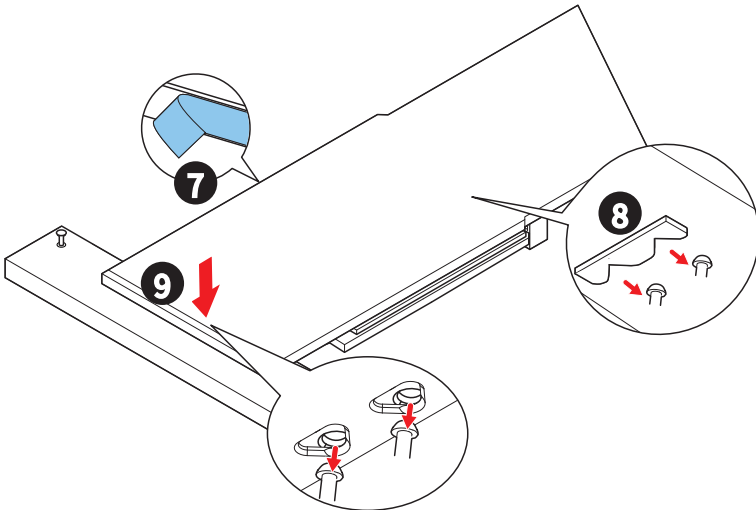

**!** **Important**

Please remove all rubber cubes from the M.2 plates before installing the Screwless M.2 Shield Frozr heatsink.

## Installing M.2 module into M2\_5 slot

1. Press and hold the end button of Screwless M.2 Shield Frozr heatsink.

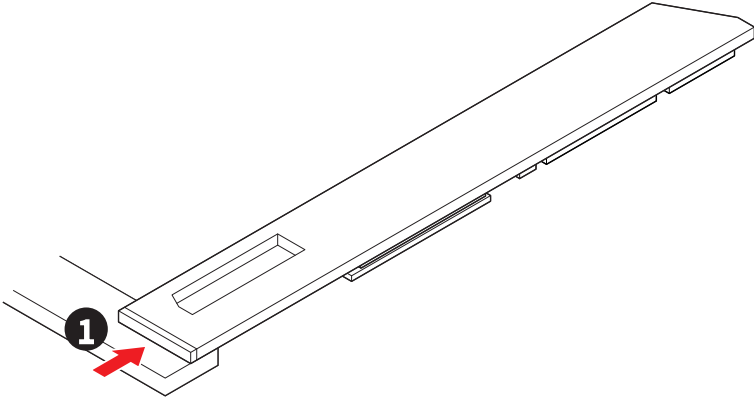

2. Slightly lift up the end part of Screwless M.2 Shield Frozr heatsink and move it forward to uninstall the heatsink.

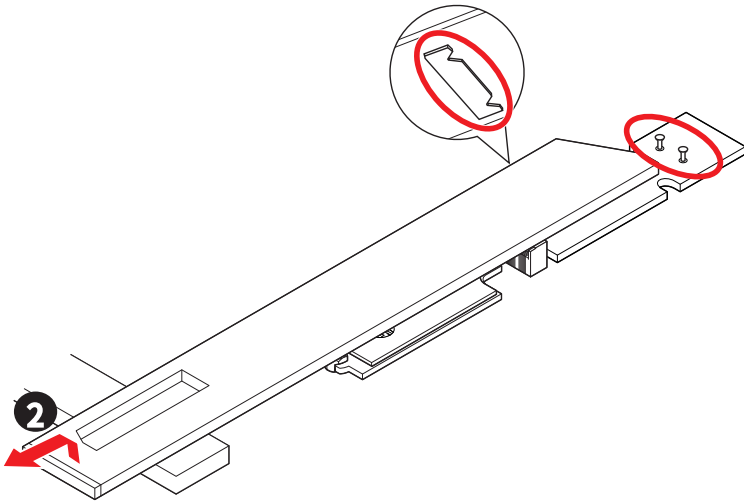

3. Remove the protective film from the M.2 thermal pads on the M.2 plate.

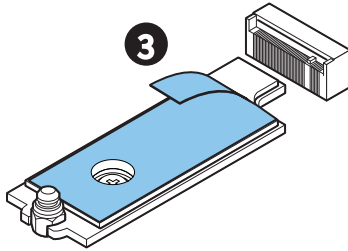

4. If you install 2260 SSD, exchange the **EZ M.2 Clip II** and the plate screw. Please note that you have to use the **EZ M.2 Chip II Remover** to remove and install the **EZ M.2 Clip II**. Skip this step if you install 2280 SSD.

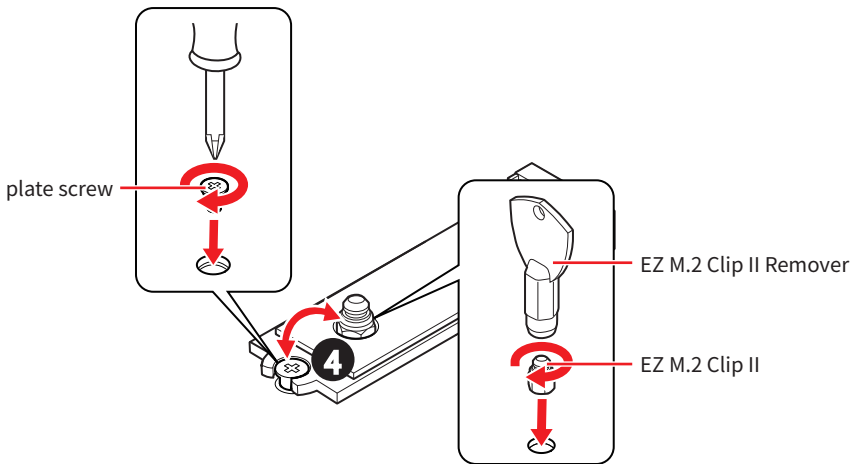

5. Insert your M.2 SSD into the M.2 slot at a 30-degree angle.
6. Use the EZ M.2 Clip II to lock and secure the SSD.

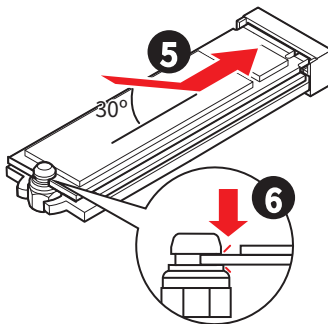

7. Remove the protective films from the thermal pads under Screwless M.2 Shield Frozr heatsink.
8. Align the notches under Screwless M.2 Shield Frozr heatsink with the tenons, and then put the heatsink back in place.
9. Press the end side of Screwless M.2 Shield Frozr heatsink to lock it completely.

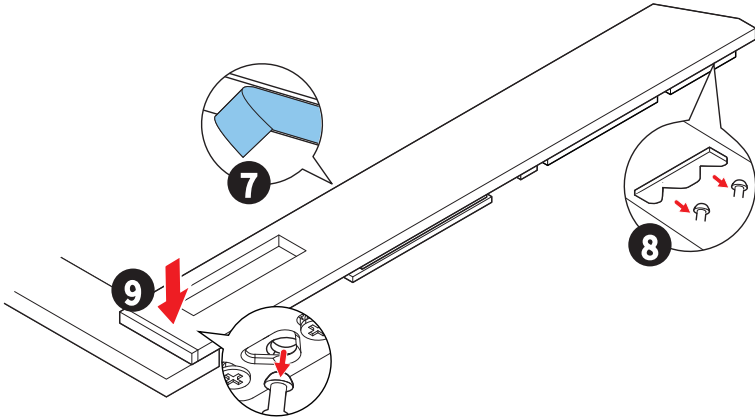

### Removing M.2 SSD using the EZ M.2 Clip II

To remove M.2 SSD from the EZ M.2 Clip II, gently push the spring head on the top of the EZ M.2 Clip II outward while simultaneously pulling the M.2 SSD out.

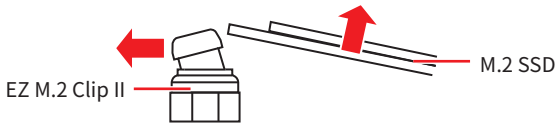

## SATA\_P3~P4 & SATA\_S3~S4: SATA 6Gb/s Connectors

These connectors are SATA 6Gb/s interface ports. Each connector can connect to one SATA device.

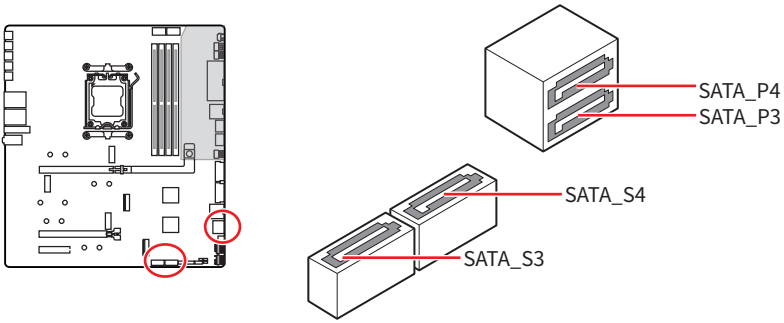

### Important

- Please do not fold the SATA cable at a 90-degree angle. Data loss may result during transmission otherwise.
- SATA cables have identical plugs on either sides of the cable. However, it is recommended that the flat connector be connected to the motherboard for space saving purposes.

## JAUD1: Front Audio Connector

This connector allows you to connect audio jacks on the front panel.

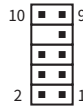
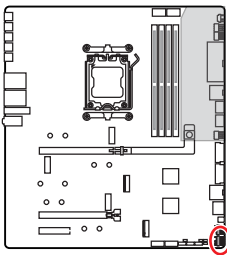

Pin	Signal Name	Pin	Signal Name
1	MIC L	2	Ground
3	MIC R	4	NC
5	Head Phone R	6	MIC Detection
7	SENSE_SEND	8	No Pin
9	Head Phone L	10	Head Phone Detection

## JFP1, JFP2: Front Panel Connectors

The JFP1 connector controls the power on, power reset, and the LEDs on your PC case/chassis. Power Switch/ Reset Switch headers allow you to connect power button/ reset button. Power LED header connects to LED light on the PC case, and HDD LED header indicates the activity of the hard disk. The JFP2 connector is for Buzzer and Speaker. For connecting the cables from your PC case to the correct pins on the motherboard, please refer to the following images.

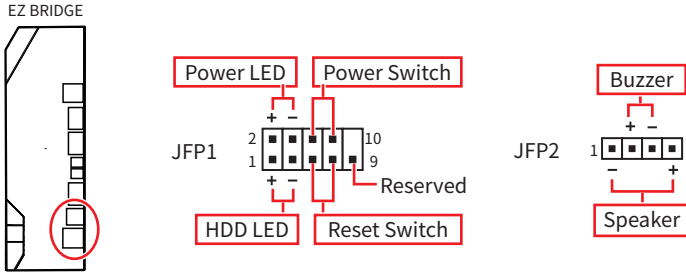

### Important

Make sure to connect the Power LED and HDD LED cables to the corresponding positive and negative pins on the motherboard. Otherwise, the LEDs will not function properly.

## Using EZ Front Panel Cable

The **EZ Front Panel Cable** allows you to first connect and integrate the PC case's front panel connectors, making it easier to install into the **JFP1** connector. Attach **Power SW**, **Reset SW**, **Power LED (+ to +, - to -)**, and **HDD LED (+ to +, - to -)** to the matching pins on the Front Panel Cable, then plug the **EZ Front Panel Cable** into the **JFP1** connector.

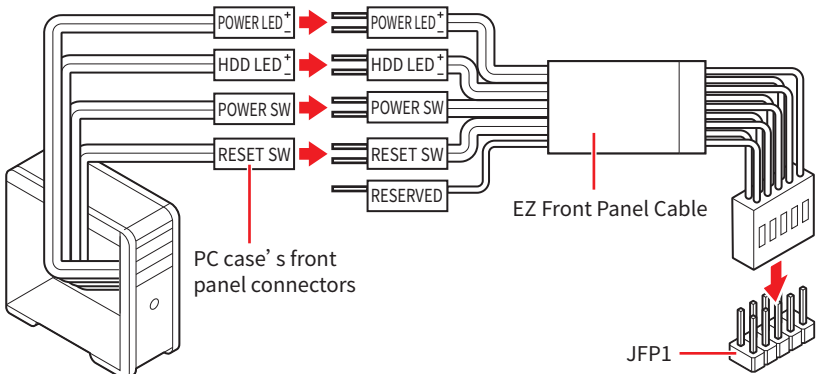

# CPU\_PWR1~2, ATX\_PWR1, PCIE\_PWR1, PD\_PWR1, JSATA\_PWR1: Power Connectors

These power connectors allow you to connect an ATX power supply.

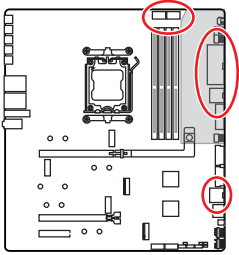

EZ CONTROL HUB

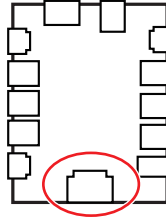

CPU\_PWR1~2

CPU\_PWR1~2

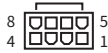

Pin	Signal Name	Pin	Signal Name
1	Ground	2	Ground
3	Ground	4	Ground
5	+12V	6	+12V
7	+12V	8	+12V

ATX\_PWR1

ATX\_PWR1

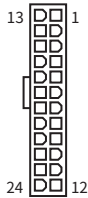

Pin	Signal Name	Pin	Signal Name
1	+3.3V	2	+3.3V
3	Ground	4	+5V
5	Ground	6	+5V
7	Ground	8	PWR OK
9	5VSB	10	+12V
11	+12V	12	+3.3V
13	+3.3V	14	-12V
15	Ground	16	PS-ON#
17	Ground	18	Ground
19	Ground	20	Res
21	+5V	22	+5V
23	+5V	24	Ground

## PCIE\_PWR1/ PD\_PWR1

PCIE\_PWR1/  
PD\_PWR1



Pin	Signal Name	Pin	Signal Name
1	+12V	2	+12V
3	+12V	4	SENS1
5	Ground	6	SENS0
7	Ground	8	Ground

## JSATA\_PWR1

JSATA\_PWR1

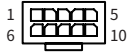

Pin	Signal Name	Pin	Signal Name
1	+12V	2	+12V
3	+12V	4	+5V
5	+5V	6	Ground
7	Ground	8	Ground
9	Ground	10	Ground

### Important

Make sure that all the power cables are securely connected to a proper ATX power supply to ensure stable operation of the motherboard.

## JSATA\_PWR1 Connection

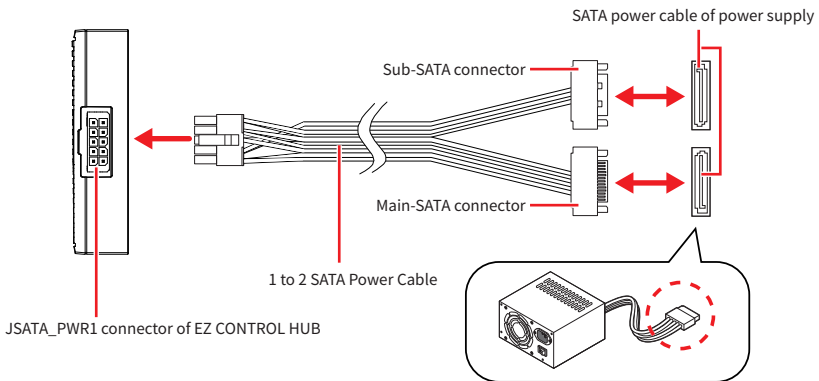

### Important

If your power supply only has one free SATA power cable, always connect it to the Main- SATA connector first.

## JBRG\_HUB1: EZ Link Connector

These connectors are specifically designed to connect EZ BRIDGE and EZ CONTROL HUB.

EZ BRIDGE

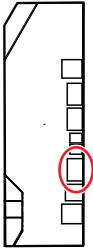

EZ CONTROL HUB

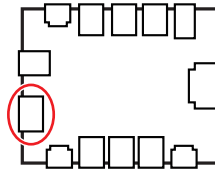

## EZ BRIDGE & EZ CONTROL HUB Connection

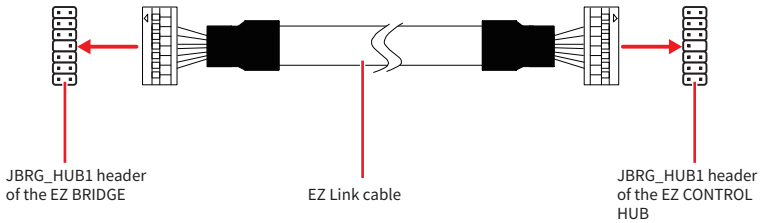

Watch the video to learn how to connect the EZ BRIDGE and EZ CONTROL HUB.

- <https://msi.gm/S4099795>

## JCI1: Chassis Intrusion Connector

This connector allows you to connect the chassis intrusion switch cable.

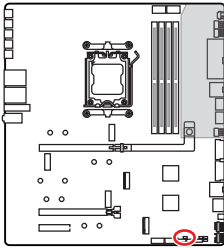

Normal  
(default)



Trigger the chassis  
intrusion event

### Using chassis intrusion detector

1. Connect the **JCI1** connector to the chassis intrusion switch/ sensor on the chassis.
2. Close the chassis cover.
3. Go to **BIOS > Security > Chassis Intrusion Configuration**.
4. Set **Chassis Intrusion** to **Enabled**.
5. Press **F10** to save and exit and then press the **Enter** key to select **Yes**.
6. Once the chassis cover is opened again, a warning message will be displayed on screen when the computer is turned on.

### Resetting the chassis intrusion warning

1. Go to **BIOS > Security > Chassis Intrusion Configuration**.
2. Set **Chassis Intrusion** to **Reset**.
3. Press **F10** to save and exit and then press the Enter key to select **Yes**.

## JOCFS1: Safe Boot Jumper

This jumper is used for Safe Boot. When this jumper is enabled, the system will boot with default settings and lower PCIe (from CPU) mode.

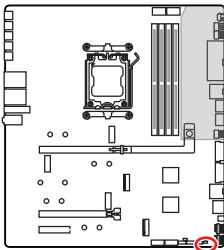

Normal (default)  
Boot with the saved  
BIOS settings.



Enabled  
Apply the BIOS default  
settings and lower PCIe  
(from CPU) mode for  
Safe Boot

## JUSBC1~C2: USB Type-C® Front Panel Connectors

These USB connectors allow you to connect to the USB Type-C® ports on the front panel and support data transfer speeds of up to 20Gbps (for JUSBC2)/ 10Gbps (for JUSBC1). It features a user-friendly design that ensures proper orientation when connecting the cable.

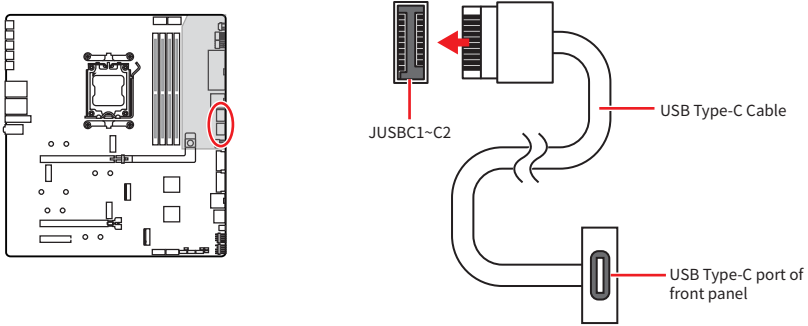

### Important

To achieve USB PD 60W fast charging for JUSBC2 port, the PD\_PWR1 connector needs to be connected to the power supply unit.

## JUSB2~3: USB 5Gbps Connector

This USB connector allows you to connect to USB ports on the chassis panel and supports data transfer speeds of up to 5Gbps.

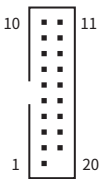
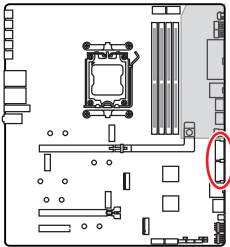

Pin	Signal Name	Pin	Signal Name
1	Power	2	USB3_RX_DN
3	USB3_RX_DP	4	Ground
5	USB3_TX_C_DN	6	USB3_TX_C_DP
7	Ground	8	USB2.0-
9	USB2.0+	10	Ground
11	USB2.0+	12	USB2.0-
13	Ground	14	USB3_TX_C_DP
15	USB3_TX_C_DN	16	Ground
17	USB3_RX_DP	18	USB3_RX_DN
19	Power	20	No Pin

### Important

Note that the Power and Ground pins must be connected correctly to avoid possible damage.

## JUSB1 & JUSB\_BRG\_1: USB 2.0 Connector

This USB connector allows you to connect to USB ports on the chassis panel and supports data transfer speeds of up to 480Mbps.

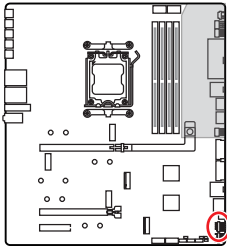

EZ BRIDGE

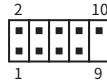
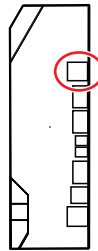

Pin	Signal Name	Pin	Signal Name
1	VCC	2	VCC
3	USB0-	4	USB1-
5	USB0+	6	USB1+
7	Ground	8	Ground
9	No Pin	10	NC

### **Important**

- Note that the VCC and Ground pins must be connected correctly to avoid possible damage.
- In order to recharge your iPad, iPhone and iPod through USB ports, please install MSI Center utility.

## CPU\_FAN1, PUMP\_SYS1~2, SYS\_FAN1~7: Fan Connectors

Fan connectors can be divided into two categories: PWM Mode and DC Mode. PWM Mode fan connectors provide a constant 12V output and adjust fan speed with a speed control signal. DC Mode fan connectors control fan speed by changing voltage. Please refer to the following specification table for the fan connector mode of your motherboard.

You can control fans in **BIOS> HARDWARE MONITOR** panel. Enabling Smart Fan Mode will regulate fan speed based on CPU or system temperature. Disabling Smart Fan Mode will set the fan to full speed.

### Important

You can set DC or PWM in **HARDWARE MONITOR** panel to your fan type if your motherboard supports it. Make sure fans are working properly after switching the PWM/ DC mode.

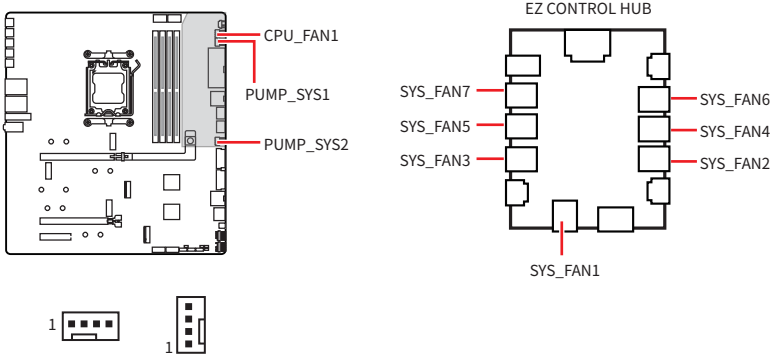

### PWM Mode pin definition

Pin	Signal Name	Pin	Signal Name
1	Ground	2	+12V
3	Sense	4	Speed Control Signal

### DC Mode pin definition

Pin	Signal Name	Pin	Signal Name
1	Ground	2	Voltage Control
3	Sense	4	NC

### Fan specifications for fan connectors

Connector	Fan mode	Max. current	Max. power
CPU_FAN1	Auto mode	2A	24W
PUMP_SYS1~2	PWM mode	3A	36W
SYS_FAN1~7	Auto mode	1A	12W

### Important

The auto mode fan connectors can automatically detect PWM and DC modes.

# JBAT1: Clear CMOS (Reset BIOS) Jumper

There is CMOS memory onboard that is external powered from a battery located on the motherboard to save system configuration data. If you want to clear the system configuration, set the jumpers to clear the CMOS memory.

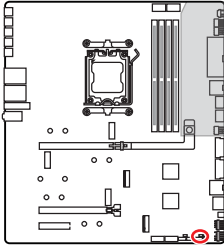

Keep Data  
(default)



Clear CMOS/  
Reset BIOS

## Resetting BIOS to default values

1. Power off the computer and unplug the power cord.
2. Use a jumper cap to short **JBAT1** for about 5-10 seconds.
3. Remove the jumper cap from **JBAT1**.
4. Plug the power cord and Power on the computer.

## W\_FLOW1: Water Flow Meter Connector

This connector allows you to connect a water flow meter to monitor the flow rate of your liquid cooling system.

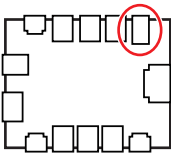

EZ CONTROL HUB





Pin	Signal Name	Pin	Signal Name
1	Ground	2	WFLOW PWR
3	WFLOW IN		

## JLN1: Low Temperature Booting Jumper

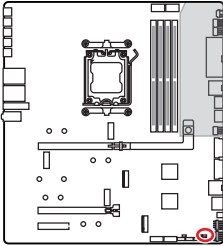
This jumper allows liquid nitrogen cooling system to boot at an extremely low temperature. Please try to enable the jumper to help the system boot successfully.



  
Normal  
(Default)

  
Enabled  
(Please enable this jumper during BIOS POST)

### **Important**

- Please note that overclocking at an extremely low temperature carries the risk of system instability and may cause damages to the system.
- The overclocking results may vary depending on the CPU you use.
- Do not enable the jumper when the system is power off. Otherwise, the system will be unbootable.

## T\_SEN1~2: Thermal Sensor Connectors

These connectors allow you to connect the thermistor cable and use it to monitor the temperature of the detection point.

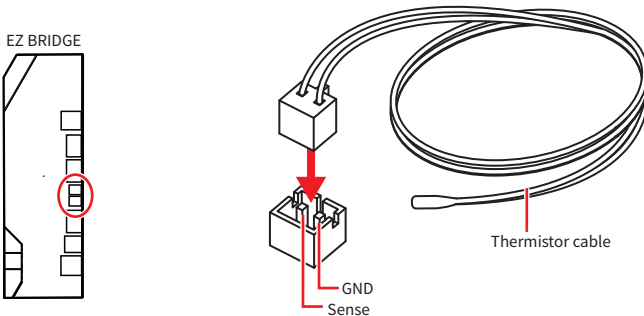

## JDASH1 : Tuning Controller connector

This connector is used to connect an optional Tuning Controller module.

EZ BRIDGE

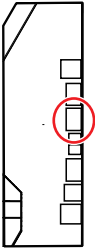

Pin	Signal Name	Pin	Signal Name
1	No Pin	2	NC
3	MCU_SMB_SCL_M	4	MCU_SMB_SDA_M
5	VCC5	6	Ground
7	PSIN#_R	8	FP_RST#_R
9	OC_RETRY#	10	OC_FS
11	BLK+	12	BLK-
13	CLRCMOS_EN	14	NC

## POWER1, RESET1: Power Button, Reset Button

The Power/ Reset button allows you to power on/ reset the computer.

EZ BRIDGE

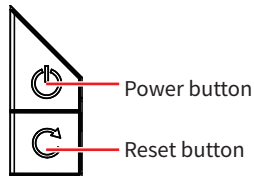
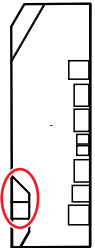

## V-Check Points Lite

These voltage checkpoints are used to measure the current system voltages. A multimeter (not included) will be required to check voltages. To measure voltage, place test leads on the GND (screw mounting hole) and a specific V-Check Point. Please refer to the manual of your multimeter for more information.

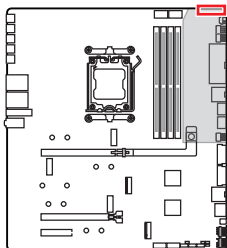

- GND
- DDR1
- SOC1
- CORE1

# M.2 XPANDER-Z SLIDER GEN5 card

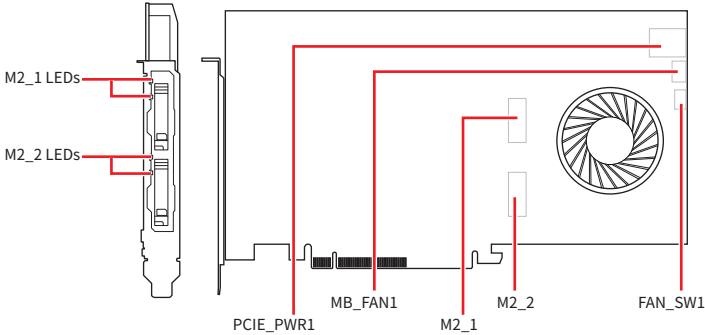

## Specifications

<b>Interface</b>	<ul style="list-style-type: none"> <li>• 2x M.2 slots (Key M)</li> <li>• Supports up to PCIe 5.0 x 4*</li> <li>• Supports 2280 M.2 SSD**</li> </ul> <p>* The operating speed depends on the PCIe slot specification of your motherboard.</p> <p>** Only support the M.2 SSD as the data disk.</p>
<b>External connectors</b>	<ul style="list-style-type: none"> <li>• 1x 6-pin ATX PCIe power connector</li> <li>• 1x Fan synchronous connector</li> <li>• For connecting the system fan connector on the motherboard</li> </ul>
<b>Switch</b>	<ul style="list-style-type: none"> <li>• 1x Fan switch</li> <li>• Turn on/ off the heatsink fan</li> </ul>
<b>LEDs</b>	<ul style="list-style-type: none"> <li>• 2x M.2 LED sets</li> <li>• Off - M.2 SSD is not detected</li> <li>• Aqua blue - M.2 SSD has been detected</li> <li>• Blue blinking - M.2 SSD is accessing data</li> </ul>
<b>Form Factor</b>	<ul style="list-style-type: none"> <li>• 242 x 135 x 18.57 mm</li> </ul>

### Important

- This card does not support the M.2 SSD with the heatsink.
- This card does not support M.2 enclosure hot-plug.
- The M.2 SSDs in this card are exclusively for data storage.

## Install the M.2 SSD & Xpander-Z Slider Gen 5 card

1. Unlock the M.2 enclosure side cover.
2. Hold the side cover and pull the M.2 enclosure out.

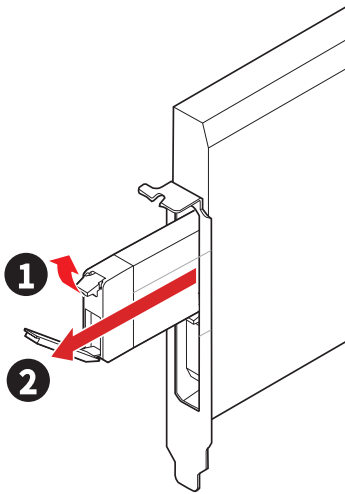

3. Unlock the M.2 enclosure top cover.
4. Lift the cover and move it forward to uninstall it.
5. Remove the protective film from the thermal pad inside the M.2 enclosure.

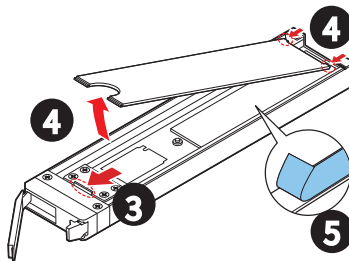

Watch the video to learn how to install the M.2 XPANDER-Z SLIDER GEN5 card.

- <https://msi.gm/SBC78842>

6. Please ensure the notch position of the M.2 SSD contacts to correctly install the M.2 SSD into the M.2 enclosure.

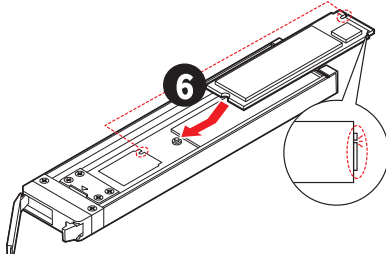

**Important**

*All contacts of the M.2 SSD must be fully exposed after you install the M.2 SSD.*

7. Remove the protective film from the bottom of the top cover.
8. Reinstall the top cover back and ensure it be locked.

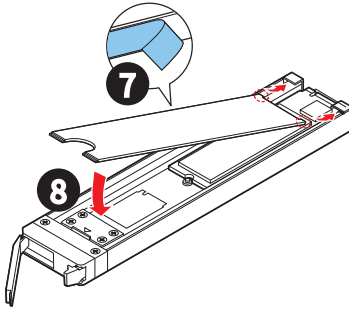

- Align the alignment marks on the M.2 enclosure and M.2 bracket. Install the M.2 enclosure back into the slot until it is locked in place.
- Push the M.2 side cover back to lock the M.2 enclosure.

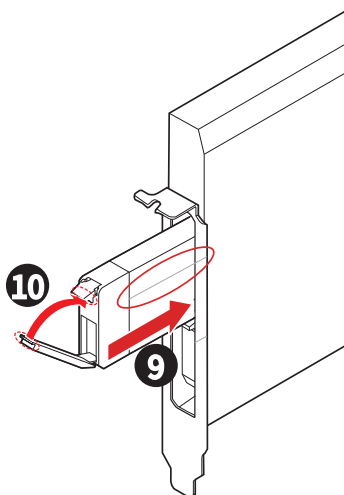

- Install the XPANDER-Z SLIDER GEN5 card into the PCIe slot on the motherboard.
- Connect the PCIE\_PWR1 connector to the power supply.

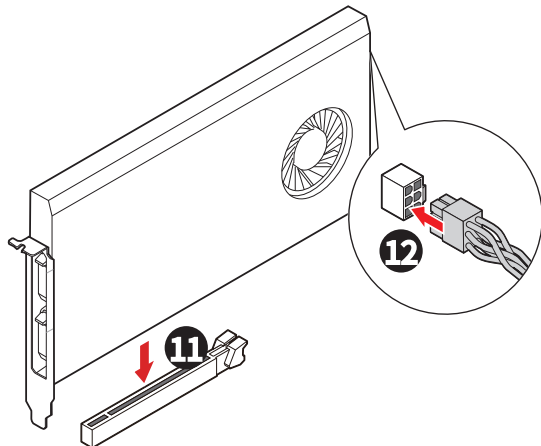

**!** **Important**

*If the system fails to detect the M.2 SSD, please attempt to replace the thermal pad. We provide thermal pads in two varying thicknesses. To ensure a successful connection with the M.2 SSD, please select the appropriate thickness based on your M.2 SSD requirement.*

## BIOS\_SW1: Multi-BIOS Switch

This motherboard has two built-in BIOS ROMs. If one is crashed, you can shift to the other for booting by sliding the switch.

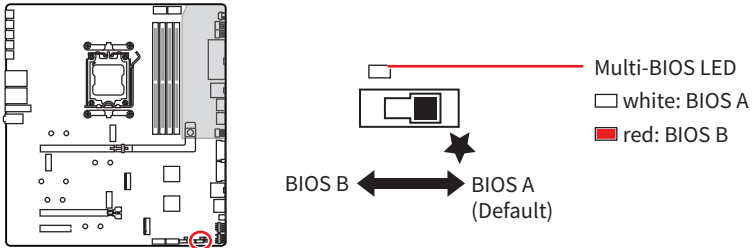

### Important

- Do not use the Multi-BIOS switch when system is booting up.
- You can also use the **MSI Center** or **Flash BIOS Button** to flash BIOS. Please refer to BIOS section for details.

## JDASH\_SW1: Module Selector Switch

This switch is used to switch between Dynamic Dashboard III & Tuning Controller module.

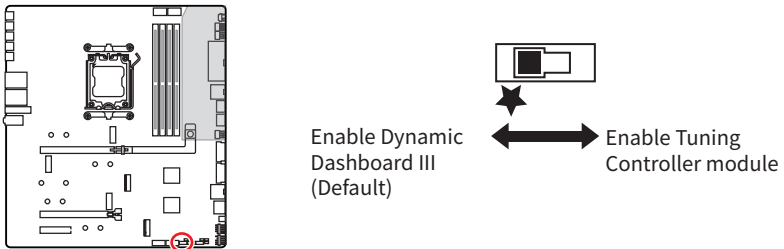

# JRGB1: RGB LED connector

The JRGB connector allows you to connect the 5050 RGB LED strips 12V.

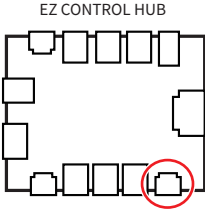

Pin	Signal Name	Pin	Signal Name
1	+12V	2	G
3	R	4	B

## RGB LED Strip Connection

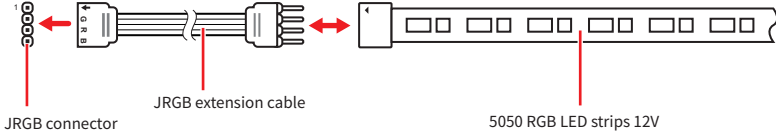

## RGB LED Fan Connection

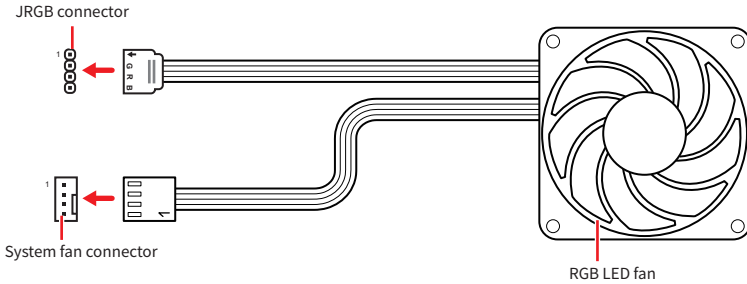

### Important

- The JRGB connector supports up to 2 meters continuous 5050 RGB LED strips (12V/G/R/B) with the maximum power rating of 3A (12V).
- Always turn off the power supply and unplug the power cord from the power outlet before installing or removing the RGB LED strip.
- Please use MSI's software to control the extended LED strip.

# JARGB\_V2\_1~3: A-RAINBOW V2 (ARGB Gen2) LED connectors

The JARGB\_V2 connectors allow you to connect the ARGB Gen2 and the ARGB-based LED strips. The JARGB\_V2 connector supports up to 180 individually addressable RGB LEDs with maximum power rating of 3A (5V).

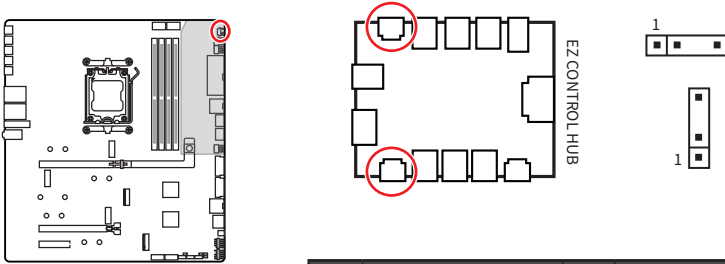

Pin	Signal Name	Pin	Signal Name
1	+5V	2	Data
3	No Pin	4	Ground

## Addressable RGB LED Strip Connection

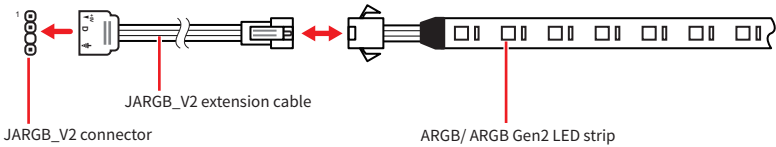

## Addressable RGB LED Fan Connection

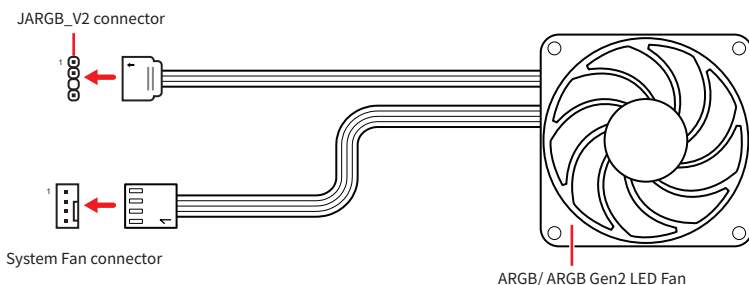

### CAUTION

Do not connect the wrong type of LED strips. The JRGB connector and the JARGB\_V2 connector provide different voltages, and connecting the ARGB 5V LED strip to the JRGB connector will result in damage to the LED strip.

### Important

- If you connect the ARGB Gen1 and ARGB Gen2 LED strips into the same connector, it may cause some issues. Please do not mix the ARGB Gen1 LED and the ARGB Gen2 LED strips together.
- It is recommended that you install LED strips with the same specification to achieve the best effects.
- Always turn off the power supply and unplug the power cord from the power outlet before installing or removing the addressable RGB LED strip.
- Please use MSI's software to control the extended LED strip.

## JAF\_2: EZ Conn-Header V2

This header allows you to connect the ARGB Gen1 and Gen2 LED strips, fans and USB 2.0 devices. It can also be used to connect MPG EZ120 ARGB fans.

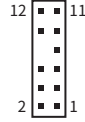
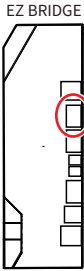

Pin	Signal Name	Pin	Signal Name
1	Ground	2	5V
3	12V	4	DATA
5	Sense	6	Ground
7	Speed	8	N/A
9	Ground	10	USB 2.0+
11	+5VSB	12	USB 2.0-

## Addressable RGB LED Fan Connection

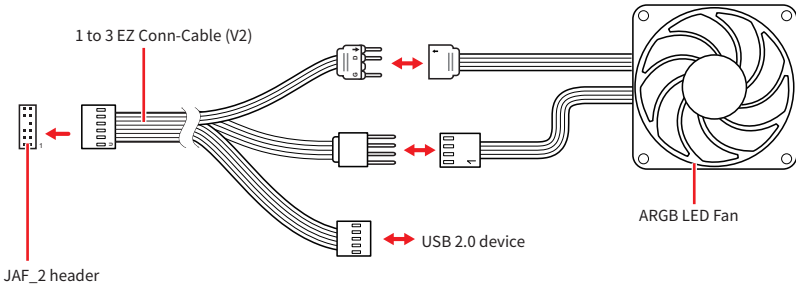

## MPG EZ120 ARGB Fan Connection

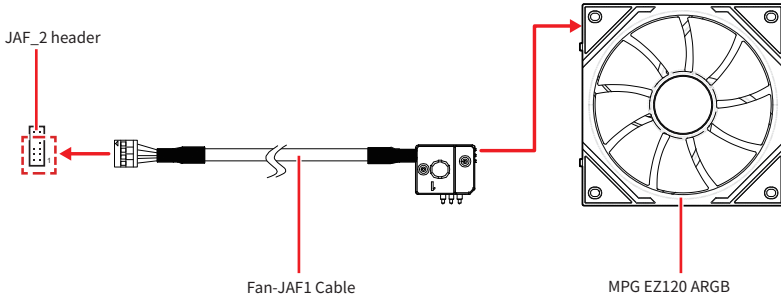

### **Important**

- The Fan-JAF1 Cable is included in the packaging of MPG EZ120 ARGB.
- JAF\_2 header is compatible with JAF\_1 header since pins 1 to 7 carry the same signals. MPG EZ120 ARGB can be connected to the JAF\_2 header.
- For more information on how to install MPG EZ120 ARGB, please refer to <https://msi.gm/S5035E56>.

## JPWRLED1: LED power input

This connector is used by retailers to demonstrate onboard LED lights.

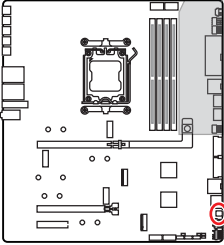

## LED\_SW1: EZ LED Control

This switch is used to switch on/ off all the LEDs on the motherboard.

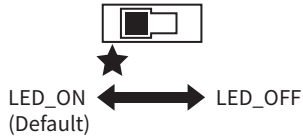
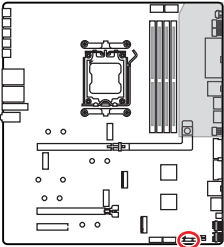

## DYNAMIC DASHBOARD III

The DYNAMIC DASHBOARD III, a TFT LCD panel, is located on the EZ BRIDGE. It can display system status, temperatures, voltages, BIOS flash status and error messages. You can use MSI Center to configure and customize the displays of the DYNAMIC DASHBOARD III and even upload a .gif/ .bmp/ .png/ .jpg or .mp4 animation file.

### Booting screen

DYNAMIC DASHBOARD III will display the progress and error codes during booting and POST. Please refer to the following Debug Code LED table for details.



### Main screen

Before installing MSI Center, the main screen of DYNAMIC DASHBOARD III will display some default information as Fig.1 below.

After installing MSI Center, you can configure the hardware monitoring data in MSI Center to be displayed as the main screen of DYNAMIC DASHBOARD III.

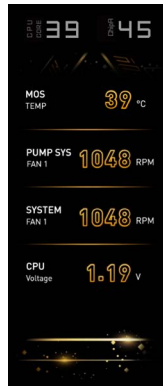

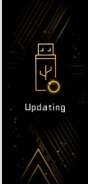







Fig.1

## DYNAMIC DASHBOARD III Status Table

System Status	DYNAMIC DASHBOARD III	System Status	DYNAMIC DASHBOARD III
Power On		Flash BIOS (Update)	
CPU/ DDR is not detected or fail		System Clock page	
Graphics card is not detected or fail		Dynamic Dashboard III is disabled by JDASH_SW1 (P.67)	
S4/S5 (Suspend to Disk/ Shutdown) S3 (Suspend to Ram)		User profile	<div style="border: 1px dashed black; width: 100px; height: 100px; margin: 0 auto;"></div> <p>480*800px.gif / 1bmp/ jpg/ png/ / mp4</p>
Hardware Monitor page			

### Important

To take full advantage of DYNAMIC DASHBOARD III, you should to install MSI Center and then install the DYNAMIC DASHBOARD APP within MSI Center ( MSI Center > Feature Sets > DYNAMIC DASHBOARD).

## Debug Code LED Table

The Debug Code LED displays progress and error codes during and after POST. Refer to the Debug Code LED table for details.

### SEC Progress Codes

01	Power on. Reset type detection (soft/hard)
02	AP initialization before microcode loading
03	System Agent initialization before microcode loading
04	PCH initialization before microcode loading
06	Microcode loading
07	AP initialization after microcode loading
08	System Agent initialization after microcode loading
09	PCH initialization after microcode loading
0B	Cache initialization

### SEC Error Codes

0C - 0D	Reserved for future AMI SEC error codes
0E	Microcode not found
0F	Microcode not loaded

### PEI Progress Codes

10	PEI Core is started
11	Pre-memory CPU initialization is started
12 - 14	Pre-memory CPU initialization (CPU module specific)
15	Pre-memory System Agent initialization is started
16 - 18	Pre-Memory System Agent initialization (System Agent module specific)
19	Pre-memory PCH initialization is started
1A - 1C	Pre-memory PCH initialization (PCH module specific)
2B	Memory initialization. Serial Presence Detect (SPD) data reading
2C	Memory initialization. Memory presence detection
2D	Memory initialization. Programming memory timing information
2E	Memory initialization. Configuring memory
2F	Memory initialization (other)
31	Memory Installed
32	CPU post-memory initialization is started
33	CPU post-memory initialization. Cache initialization
34	CPU post-memory initialization. Application Processor(s) (AP) initialization
35	CPU post-memory initialization. Boot Strap Processor (BSP) selection

<b>36</b>	CPU post-memory initialization. System Management Mode (SMM) initialization
<b>37</b>	Post-Memory System Agent initialization is started
<b>38 - 3A</b>	Post-Memory System Agent initialization (System Agent module specific)
<b>3B</b>	Post-Memory PCH initialization is started
<b>3C - 3E</b>	Post-Memory PCH initialization (PCH module specific)
<b>4F</b>	DXE IPL is started

### PEI Progress Codes

<b>10</b>	Memory not installed
-----------	----------------------

### DXE Progress Codes

<b>60</b>	DXE Core is started
<b>61</b>	NVRAM initialization
<b>62</b>	Installation of the PCH Runtime Services
<b>63</b>	CPU DXE initialization is started
<b>64 - 67</b>	CPU DXE initialization (CPU module specific)
<b>68</b>	PCI host bridge initialization
<b>69</b>	System Agent DXE initialization is started
<b>6A</b>	System Agent DXE SMM initialization is started
<b>6B - 6F</b>	System Agent DXE initialization (System Agent module specific)
<b>70</b>	PCH DXE initialization is started
<b>71</b>	PCH DXE SMM initialization is started
<b>72</b>	PCH devices initialization
<b>73 - 77</b>	PCH DXE Initialization (PCH module specific)
<b>78</b>	ACPI module initialization
<b>79</b>	CSM initialization
<b>7A - 7F</b>	Reserved for future AMI DXE codes
<b>90</b>	Boot Device Selection (BDS) phase is started
<b>91</b>	Driver connecting is started
<b>92</b>	PCI Bus initialization is started
<b>93</b>	PCI Bus Hot Plug Controller Initialization
<b>94</b>	PCI Bus Enumeration 32
<b>95</b>	PCI Bus Request Resources
<b>96</b>	PCI Bus Assign Resources
<b>97</b>	Console Output devices connect
<b>98</b>	Console input devices connect

<b>99</b>	Super IO Initialization
<b>9A</b>	USB initialization is started
<b>9B</b>	USB Reset
<b>9C</b>	USB Detect
<b>9D</b>	USB Enable
<b>9E -9F</b>	Reserved for future AMI codes
<b>A0</b>	IDE initialization is started
<b>A1</b>	IDE Reset
<b>A2</b>	IDE Detect
<b>A3</b>	IDE Enable
<b>A4</b>	SCSI initialization is started
<b>A5</b>	SCSI Reset
<b>A6</b>	SCSI Detect
<b>A7</b>	SCSI Enable
<b>A8</b>	Setup Verifying Password
<b>A9</b>	Start of Setup
<b>AB</b>	Setup Input Wait
<b>AD</b>	Ready To Boot event
<b>AE</b>	Legacy Boot event
<b>AF</b>	Exit Boot Services event
<b>B0</b>	Runtime Set Virtual Address MAP Begin
<b>B1</b>	Runtime Set Virtual Address MAP End
<b>B2</b>	Legacy Option ROM Initialization
<b>B3</b>	System Reset
<b>B4</b>	USB hot plug
<b>B5</b>	PCI bus hot plug
<b>B6</b>	Clean-up of NVRAM
<b>B7</b>	Configuration Reset (reset of NVRAM settings)
<b>B8 - BF</b>	Reserved for future AMI codes

#### **DXE Error Codes**

<b>D0</b>	CPU initialization error
<b>D1</b>	System Agent initialization error
<b>D2</b>	PCH initialization error
<b>D3</b>	Some of the Architectural Protocols are not available

<b>D4</b>	PCI resource allocation error. Out of Resources
<b>D5</b>	No Space for Legacy Option ROM
<b>D6</b>	No Console Output Devices are found
<b>D7</b>	No Console Input Devices are found
<b>D8</b>	Invalid password
<b>D9</b>	Error loading Boot Option (LoadImage returned error)
<b>DA</b>	Boot Option is failed (StartImage returned error)
<b>DB</b>	Flash update is failed
<b>DC</b>	Reset protocol is not available

### S3 Resume Progress Codes

<b>E0</b>	S3 Resume is started (S3 Resume PPI is called by the DXE IPL)
<b>E1</b>	S3 Boot Script execution
<b>E2</b>	Video repost
<b>E3</b>	OS S3 wake vector call
<b>E4 - E7</b>	Reserved for future AMI progress codes

### S3 Resume Error Codes

<b>E8</b>	S3 Resume Failed
<b>E9</b>	S3 Resume PPI not Found
<b>EA</b>	S3 Resume Boot Script Error
<b>EB</b>	S3 OS Wake Error
<b>EC - EF</b>	Reserved for future AMI error codes

### Recovery Progress Codes

<b>F0</b>	Recovery condition triggered by firmware (Auto recovery)
<b>F1</b>	Recovery condition triggered by user (Forced recovery)
<b>F2</b>	Recovery process started
<b>F3</b>	Recovery firmware image is found
<b>F4</b>	Recovery firmware image is loaded
<b>F5 - F7</b>	Reserved for future AMI progress codes

### Recovery Error Codes

<b>F8</b>	Recovery PPI is not available
<b>F9</b>	Recovery capsule is not found
<b>FA</b>	Invalid recovery capsule
<b>FB - FF</b>	Reserved for future AMI error codes

## ACPI States Codes

The following codes appear after booting and the operating system into ACPI modes.

<b>01</b>	System is entering S1 sleep state
<b>02</b>	System is entering S2 sleep state
<b>03</b>	System is entering S3 sleep state
<b>04</b>	System is entering S4 sleep state
<b>05</b>	System is entering S5 sleep state
<b>10</b>	System is waking up from the S1 sleep state
<b>20</b>	System is waking up from the S2 sleep state
<b>30</b>	System is waking up from the S3 sleep state
<b>40</b>	System is waking up from the S4 sleep state
<b>AC</b>	System has transitioned into ACPI mode. Interrupt controller is in PIC mode.
<b>AA</b>	System has transitioned into ACPI mode. Interrupt controller is in APIC mode.

# Installing OS, Drivers & MSI Center

Please download and update the latest utilities and drivers at [www.msi.com](http://www.msi.com)

## Installing Windows 11

1. Power on the computer.
2. Insert the Windows 11 installation disc/ USB into your computer.
3. Press the **Restart** button on the computer case.
4. Press **F11** key during the computer POST (Power-On Self Test) to get into Boot Menu.
5. Select the Windows 11 installation disc/USB from the Boot Menu.
6. Press any key if screen shows **Press any key to boot from CD or DVD...** message. If not, please skip this step.
7. Follow the instructions on the screen to install Windows 11.

# Installing Drivers with MSI Driver Utility Installer

## **Important**

- Some new network chips have not been natively supported by Windows 11. It is recommended that the **LAN driver** be installed before installing drivers with MSI Driver Utility Installer. Please refer to [www.msi.com](http://www.msi.com) to install the LAN driver for your motherboard.
  - The MSI Driver Utility Installer will only pop up once. If you cancel or close it during the process, please refer to the Live Update chapter of the MSI Center manual to install the drivers. You can also go to [www.msi.com](http://www.msi.com) to search your motherboard and download the drivers.
  - MSI Driver Utility Installer needs to be installed over the internet.
1. Start up your computer in Windows 11.
  2. Select **Start > Settings > Windows Update**, and then select **Check** for updates.
  3. MSI Driver Utility Installer will pop up automatically.

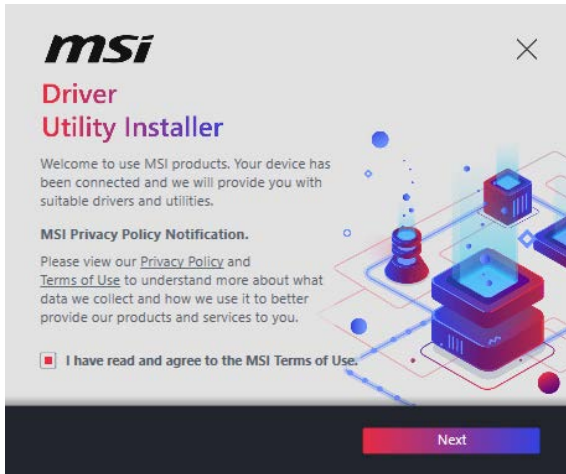

4. Select the **I have read and agree to the MSI Terms of Use** check box, and then click Next.

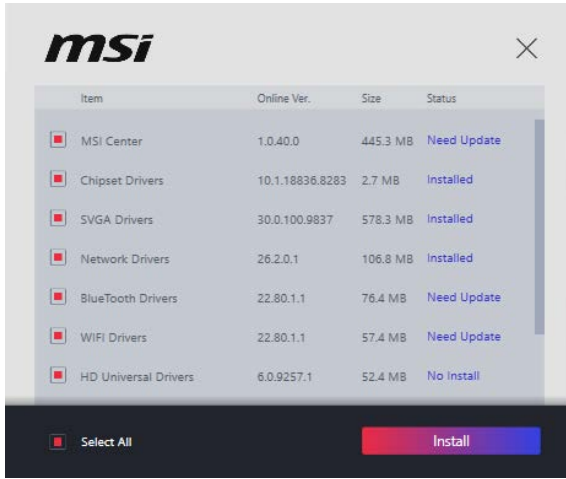

5. Check the **Select All** checkbox in the lower-left corner and click **Install** to install MSI Center and drivers. The installation progress will be shown at the bottom.

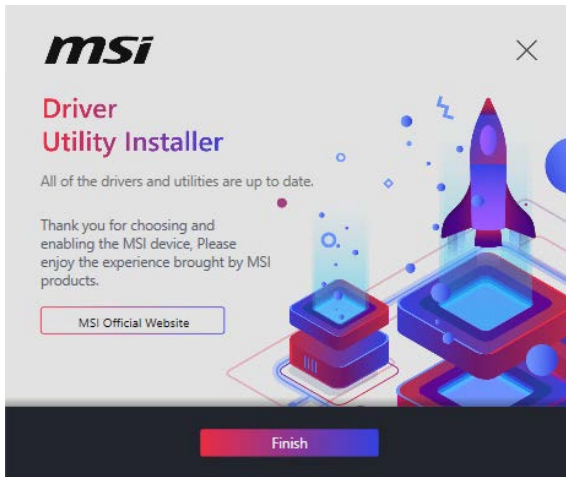

6. Once the progress has completed, click **Finish**.

## MSI Center

MSI Center is an application that helps you easily optimize game settings and smoothly use content creation softwares. It also allows you to control and synchronize LED light effects on PCs and other MSI products. With MSI Center, you can customize ideal modes, monitor system performance, and adjust fan speed.

### MSI Center User Guide



If you would like to know more information about MSI Center, please refer to <https://msi.gm/S391169E>

or scan the QR code to access.



### **Important**

*Functions may vary depending on the product you have.*

# UEFI BIOS

MSI UEFI BIOS is compatible with UEFI (Unified Extensible Firmware Interface) architecture. UEFI has many new functions and advantages that traditional BIOS cannot achieve, and it will completely replace BIOS in the future. The MSI UEFI BIOS uses UEFI as the default boot mode to take full advantage of the new chipset's capabilities. However, it still has a CSM (Compatibility Support Module) mode to be compatible with older devices. That allows you to replace legacy devices with UEFI compatible devices during the transition.

## **Important**

*The term BIOS in this user guide refers to UEFI unless otherwise noted.*

## UEFI advantages

- Fast booting - UEFI can directly boot the operating system and save the BIOS self-test process. And also eliminates the time to switch to CSM mode during POST.
- Supports for hard drive partitions larger than 2 TB.
- Supports more than 4 primary partitions with a GUID Partition Table (GPT).
- Supports unlimited number of partitions.
- Supports full capabilities of new devices - new devices may not provide backward compatibility.
- Supports secure startup - UEFI can check the validity of the operating system to ensure that no malware tampers with the startup process.

## Incompatible UEFI cases

- **32-bit Windows operating system** - this motherboard supports only Windows 11 64-bit operating system.
- **Older graphics card** - the system will detect your graphics card. If you use older graphics cards, it may display a warning message **There is no GOP (Graphics Output protocol) support detected in this graphics card.**

## **Important**

*We recommend that you replace it with a graphics card supporting GOP/UEFI or use CPU with integrated graphics for having normal function.*

## BIOS Setup

The default settings offer the optimal performance for system stability in normal conditions. You should **always keep the default settings** to avoid possible system damage or failure booting unless you are familiar with BIOS.



### **Important**

- BIOS items are continuously updated for better system performance. Therefore, the description may be slightly different from the latest BIOS and should be for reference only. You could also refer to the **HELP** information panel in BIOS.
- The BIOS screens, options and settings will vary depending on the products you have.

## BIOS User Guide



If you'd like to know more instructions on setting up the BIOS, please refer to <https://msi.gm/S53FE767> or scan the QR code to access.



### **Important**

*The appearance of the BIOS user guide may differ based on your motherboard model. Please consult your motherboard's BIOS for specific settings and options.*

# Entering BIOS Setup

Press **Delete** key, when the **Press DEL key to enter Setup Menu, F11 to enter Boot Menu** message appears on the screen during the boot process.

## Function key

**+/-**: Increase / decrease the value

**Enter**: Select the item

**ESC**: Exit

**Tab**: Next selection

**Ctrl+F**: Enter Search menu

**F1**: General Help list

**F2**: Add/ Remove a favorite item

**F3**: Enter Favorites menu

**F4**: Enter CPU core center & memory center information menu

**F5**: Enter Hardware Monitor menu

**F6**: Load optimized defaults

**F7**: Switch between Advanced mode and EZ mode

**F8**: Load Overclocking Profile

**F9**: Save Overclocking Profile

**F10**: Save Change and Reset\*

**F12**: Take a screenshot and save it to USB flash drive (FAT/ FAT32 format only).

\* Pressing **F10** displays a confirmation message summarizing your changes. Select **Yes** or **No** to confirm.

## How to find the BIOS version?

After entering the BIOS, find the BIOS version in the information box.

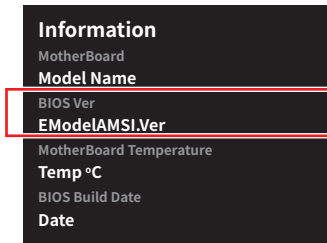

## Resetting BIOS

You might need to restore the default BIOS setting to solve certain problems. You can use the following methods to reset the BIOS settings.

- Go to BIOS and press **F6** to load optimized defaults.
- Short the **Clear CMOS** jumper on the motherboard.
- Press the **Clear CMOS** button on the rear I/O panel. If your motherboard doesn't have this button, skip this step.



### **Important**

*Be sure the computer is off before clearing CMOS data. Please refer to the **Clear CMOS jumper/ button** section for resetting BIOS.*

## Updating BIOS

### Updating BIOS with M-FLASH

Before starting the M-Flash process, make sure you have:

- A USB flash drive with a capacity of 32GB or less that is formatted to FAT32.



### **Important**

*M-Flash only supports FAT32 format, and the USB flash drive should not exceed 32GB.*

- A computer with internet access.

Please follow the steps below to update BIOS:

1. Download the latest BIOS file from the MSI website that matches your motherboard model, and save it to the USB flash drive.
2. If your motherboard has a Multi-BIOS switch, switch to the target BIOS ROM.
3. Insert the USB flash drive into your motherboard's USB port.
4. Enter flash mode by either:
  - Rebooting and pressing **Ctrl + F5** during POST, then clicking **Yes** to reboot the system.
  - Rebooting and pressing **Del** during POST to enter BIOS, then clicking the M-FLASH button and clicking **Yes** to reboot.
5. Select a BIOS file from the **M-FLASH File** menu and press **Enter**.
6. When prompted by a File Check message, click **Yes** to start the BIOS update.

Once the update reaches 100%, the system will reboot automatically.

## Updating BIOS with MSI Center

Before updating:

- Ensure the LAN driver is installed, and the internet connection is working properly.
- Close all other applications before updating the BIOS.

To update BIOS:

1. Install and launch MSI Center, then go to **Support** page.
2. Select **Live Update** and click on **Advance** button.
3. Select the BIOS file and click on **Install** button.
4. The installation reminder will appear, then click the **Install** button.

The system will automatically restart to update the BIOS. Once the flashing process is complete, the system will restart.

## Updating BIOS with Flash BIOS Button

1. Download the latest BIOS file from the MSI website that matches your motherboard model.
2. Rename the BIOS file to **MSI.ROM**, and save it to the root directory of a USB flash device.
3. Connect the power supply to **CPU\_PWR1** and **ATX\_PWR1**. (You don't need to install the CPU and memory.)
4. Plug the USB flash device with the **MSI.ROM** file into the **Flash BIOS Port** on the rear I/O panel.
5. Press the **Flash BIOS Button** to start flashing the BIOS. The LED will start flashing to indicate the process has begun.

The LED will turn off when the process is complete.

# Block Diagram

## MEG X870E GODLIKE

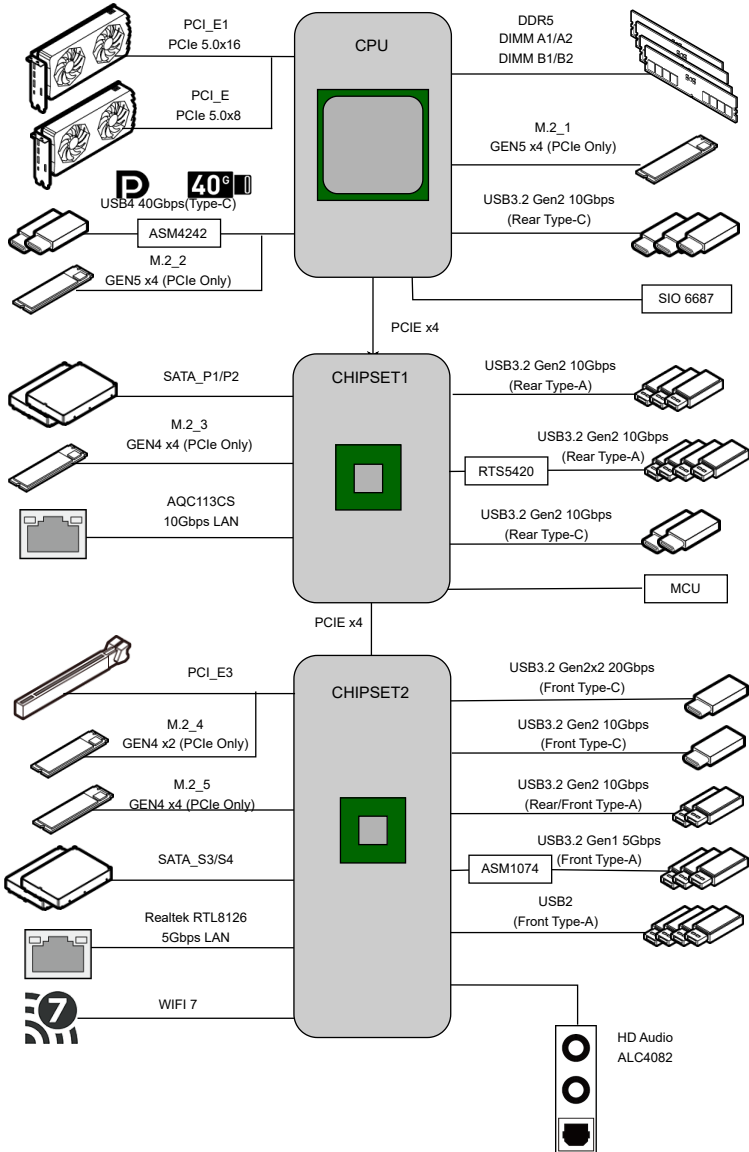

# Regulatory Notices

## FCC-B Radio Frequency Interference Statement

This equipment has been tested and found to comply with the limits for a Class B digital device, pursuant to part 15 of the FCC rules. These limits are designed to provide reasonable protection against harmful interference in a residential installation. This equipment generates, uses and radiates radio frequency energy, and, if not installed and used in accordance with the instructions, may cause harmful interference to radio communications. However, there is no guarantee that interference will not occur in a particular installation. If this equipment does cause harmful interference to radio or television reception, which can be determined by turning the equipment off and on, the user is encouraged to try to correct the interference by one or more of the following measures:



- Reorient or relocate the receiving antenna.
- Increase the separation between the equipment and receiver.
- Connect the equipment into an outlet on a circuit different from that to which the receiver is connected.

### NOTE

- The changes or modifications not expressly approved by the party responsible for compliance could void the user's authority to operate the equipment.
- Shield interface cables and AC power cord, if any, must be used in order to comply with the emission limits.

## FCC Conditions

This device complies with part 15 of the FCC Rules. Operation is subject to the following two conditions:

- This device may not cause harmful interference.
- This device must accept any interference received, including interference that may cause undesired operation.

### MSI Computer Corp.

901 Canada Court, City of Industry, CA 91748, USA

(626)913-0828

[www.msi.com](http://www.msi.com)



## CE Conformity

Products bearing the CE marking comply with one or more of the following EU Directives as may be applicable:

- RED 2014/53/EU
- Low Voltage Directive 2014/35/EU
- EMC Directive 2014/30/EU
- RoHS Directive 2011/65/EU
- Implementing measure Directive 2009/125/EC of ESPR Regulation (EU) 2024/1781



Compliance with these directives is assessed using applicable European Harmonized Standards.

For any support regarding the EU General Product Safety Regulation (GPSR), please contact MSI Computer Europe B.V. via <https://msi.gm/gpsr> Churchilllaan 202, 5705 BK Helmond, the Netherlands.

## Products with Radio Functionality (EMF)

This product incorporates a radio transmitting and receiving device. For computers in normal use, a separation distance of 20 cm ensures that radio frequency exposure levels comply with EU requirements. Products designed to be operated at closer proximities, such as tablet computers, comply with applicable EU requirements in typical operating positions. Products can be operated without maintaining a separation distance unless otherwise indicated in instructions specific to the product.

## Restrictions for Products with Radio Functionality



### WLAN 5150-5350 MHz:

The WiFi operating in the band 5150-5350 MHz shall be restricted to indoor use in the European Union.

### WLAN 7:

- a. Low Power Indoor (LPI) Wi-Fi 5.945-6.425 GHz devices:

The device is restricted to indoor use only when operating in the 5945 to 6425 MHz frequency range in the European Union.

- b. Very Low Power (VLP) Wi-Fi 5.945-6.425 GHz devices (portable devices):

The device is not permitted to be used on Unmanned Aircraft Systems (UAS) when operating in the 5945 to 6425 MHz frequency range in the European Union.

## Wireless Radio Use

This device is restricted to indoor use when operating in the 2.4GHz, 5GHz, 6GHz frequency band.

Cet appareil doit être utilisé à l'intérieur.

당해 무선설비는 운용중 전파혼신 가능성이 있음.

この製品は、周波数帯域 2.4GHz, 5GHz, 6GHz で動作しているときは、屋内においてのみ使用可能です。

### NCC無線設備警告聲明

工作頻率2.4GHz, 5GHz, 6GHz該頻段限於室內使用。

經型式認證合格之低功率射頻電機，非經許可，公司、商號或使用者均不得擅自變更頻率、加大功率或變更原設計之特性及功能。

低功率射頻電機之使用不得影響飛航安全及干擾合法通信；經發現有干擾現象時，應立即停用，並改善至無干擾時方得繼續使用。前項合法通信，指依電信法規定作業之無線電通信。低功率射頻電機須忍受合法通信或工業、科學及醫療用電波輻射性電機設備之干擾。

## Compliance Statement of Innovation, Science and Economic Development Canada (ISED)

This device complies with with Innovation, Science and Economic Development Canada's licence-exempt RSS(s). Operation is subject to the following two conditions:

(1) this device may not cause interference, and (2) this device must accept any interference, including interference that may cause undesired operation of the device.

Operation in the band 5150-5250 MHz is only for indoor use to reduce the potential for harmful interference to co-channel mobile satellite systems.

CAN ICES-003(B)/NMB-003(B)

## Australia and New Zealand notice

This equipment incorporates a radio transmitting and receiving device. In normal use, a separation distance of 20 cm ensures that radio frequency exposure levels comply with the Australian and New Zealand Standards.

## クラスB情報技術装置

この装置は、クラスB情報技術装置です。この装置は、家庭環境で使用することを目的としていますが、この装置がラジオやテレビジョン受信機に近接して使用されると、受信障害を引き起こすことがあります。取扱説明書に従って正しい取り扱いをして下さい。

VCCI-B



## KC인증서



R-R-MSI-10-7E48

상호: (주)엠에스아이코리아  
제품명: 메인보드  
모델명: 10-7E48  
제조년월: 2024년  
제조사 및 제조국가: MSI/중국



R-R-MSI-USB3VR09

상호: (주)엠에스아이코리아  
제품명: USB FLASH DRIVE  
모델명: USB3VR09  
제조년월: 2024년  
제조사 및 제조국가: MSI/중국



R-R-MSI-10-4491

상호: (주)엠에스아이코리아  
제품명: EZ CONTROL HUB  
모델명: 10-4491  
제조년월: 2024년  
제조사 및 제조국가: MSI/중국



R-R-MSI-10-4494

상호: (주)엠에스아이코리아  
제품명: M.2 XPENDER-Z SLIDER GEN5  
모델명: 10-4494  
제조년월: 2024년  
제조사 및 제조국가: MSI/중국

# Battery Information

## European Union:



Batteries, battery packs, and accumulators should not be disposed of as unsorted household waste. Please use the public collection system to return, recycle, or treat them in compliance with the local regulations.

## BSMI:



廢電池請回收

For better environmental protection, waste batteries should be collected separately for recycling or special disposal.

## California, USA:



The button cell battery may contain perchlorate material and requires special handling when recycled or disposed of in California.

For further information please visit:

<https://dtsc.ca.gov/perchlorate/>

## ⚠ WARNING

- **INGESTION HAZARD:** This product contains a button cell or coin battery.
- **DEATH** or serious injury can occur if ingested.
- A swallowed button cell or coin battery can cause **Internal Chemical Burns** in as little as **2 hours**.
- **KEEP** new and used batteries **OUT OF REACH OF CHILDREN**
- **Seek immediate medical attention** if a battery is suspected to be swallowed or inserted inside any part of the body.



- Remove and immediately recycle or dispose of used batteries according to local regulations and keep away from children. Do NOT dispose of batteries in household trash or incinerate.
- Even used batteries may cause severe injury or death. Call a local poison control center for treatment information.
- Battery type: CR2032
- Battery voltage: 3V
- Non-rechargeable batteries are not to be recharged.
- Do not force discharge, recharge, disassemble, heat above (manufacturer's specified temperature rating) or incinerate. Doing so may result in injury due to venting, leakage or explosion resulting in chemical burns.
- This product contains an irreplaceable battery.
- This icon indicates that a swallowed button battery can cause serious injury or death. Please keep batteries out of sight or reach of children.



## Chemical Substances Information

In compliance with chemical substances regulations, such as the EU REACH Regulation (Regulation EC No. 1907/2006 of the European Parliament and the Council), MSI provides the information of chemical substances in products at:

<https://csr.msi.com/global/index>

## Environmental Policy

- The product has been designed to enable proper reuse of parts and recycling and should not be thrown away at its end of life.
- Users should contact the local authorized point of collection for recycling and disposing of their end-of-life products.
- Visit the MSI website <[https://csr.msi.com/global/pevn\\_ewaste](https://csr.msi.com/global/pevn_ewaste)> and locate a nearby distributor for further recycling information.
- Please visit <<https://us.msi.com/page/recycling>> for information regarding the recycling of your product in the US.



## WEEE (Waste Electrical and Electronic Equipment) Statement



**European Union:** This symbol on the product indicates that this product cannot be discarded as municipal waste. Instead, it is your responsibility to dispose of your waste electrical and electronic equipment by handing it over to a designated collection point for recycling. For more information about where you can drop off your waste equipment for recycling, please contact your local city office, your household waste disposal service or the shop where you purchased the product.

## 日本JIS C 0950材質宣言

日本工業規格JIS C 0950により、2006年7月1日以降に販売される特定分野の電気および電子機器について、製造者による含有物質の表示が義務付けられます。

<https://csr.msi.com/tw/Japan-JIS-C-0950-Material-Declarations>

## India RoHS

This product complies with the “India E-waste (Management and Handling) Rule 2011” and prohibits use of lead, mercury, hexavalent chromium, polybrominated biphenyls or polybrominated diphenyl ethers in concentrations exceeding 0.1 weight % and 0.01 weight % for cadmium, except for the exemptions set in Schedule 2 of the Rule.

## Türkiye EEE yönetmeliği

Türkiye Cumhuriyeti: EEE Yönetmeliğine Uygundur

## Україна обмеження на наявність небезпечних речовин

Обладнання відповідає вимогам Технічного регламенту щодо обмеження використання деяких небезпечних речовин в електричному та електронному обладнанні, затвердженого постановою Кабінету Міністрів України від 3 грудня 2008 № 1057.

## Việt Nam RoHS

Kể từ ngày 01/12/2012, tất cả các sản phẩm do công ty MSI sản xuất tuân thủ Thông tư số 30/2011/TT-BCT quy định tạm thời về giới hạn hàm lượng cho phép của một số hóa chất độc hại có trong các sản phẩm điện, điện tử”

### MS-7E48主板产品中有害物质的名称及含有信息表

部件名称	有害物质									
	Pb	Hg	Cd	Cr(VI)	PBBs	PBDEs	DBP	DIBP	BBP	DEHP
电路板组件*	×	○	○	○	○	○	○	○	○	○
外部信号接头	×	○	○	○	○	○	○	○	○	○
线材	×	○	○	○	○	○	○	○	○	○
<p>注1: ○:表示该有害物质在该部件所有均质材料中的含量均不超出电器电子产品有害物质限制使用国家标准要求。</p> <p>×:表示该有害物质至少在该部件的某一均质材料中的含量超出电器电子产品有害物质限制使用国家标准要求。</p> <p>注2: 以上未列出的部件,表明其有害物质含量均不超出电器电子产品有害物质限制使用国家标准要求。</p> <p>注3: 上述表格标注“×”之部件,皆符合达标管理目录限用物质应用例外清单之限值要求。</p> <p>* 电路板组件:包括印刷电路板及其构成的零部件。</p>										

## 限用物質含有情況標示聲明書

設備名稱:電腦主機板		型號(型式):MS-7E48				
單元	限用物質及其化學符號					
	鉛 (Pb)	汞 (Hg)	鎘 (Cd)	六價鉻 (Cr <sup>6+</sup> )	多溴聯苯 (PBB)	多溴二苯醚 (PBDE)
電路板	○	○	○	○	○	○
電子元件	—	○	○	○	○	○
金屬機構件	—	○	○	○	○	○
塑膠機構件	○	○	○	○	○	○
備考1. “超出0.1 wt %”及“超出0.01 wt %”係指限用物質之百分比含量超出百分比含量基準值。 備考2. “○”係指該項限用物質之百分比含量未超出百分比含量基準值。 備考3. “—”係指該項限用物質為排除項目。						

設備名稱:USB 3.2 Gen1 隨身碟		型號(型式):VR09 3.2 Gen 1				
單元	限用物質及其化學符號					
	鉛 (Pb)	汞 (Hg)	鎘 (Cd)	六價鉻 (Cr <sup>6+</sup> )	多溴聯苯 (PBB)	多溴二苯醚 (PBDE)
儲存裝置	—	○	○	○	○	○
黑色內襯(塑件)	○	○	○	○	○	○
隨身碟外殼	○	○	○	○	○	○
備考1. “超出0.1 wt %”及“超出0.01 wt %”係指限用物質之百分比含量超出百分比含量基準值。 備考2. “○”係指該項限用物質之百分比含量未超出百分比含量基準值。 備考3. “—”係指該項限用物質為排除項目。						

## Copyright and Trademarks Notice



Copyright © Micro-Star Int'l Co., Ltd. All rights reserved. The MSI logo used is a registered trademark of Micro-Star Int'l Co., Ltd. All other marks and names mentioned may be trademarks of their respective owners. No warranty as to accuracy or completeness is expressed or implied. MSI reserves the right to make changes to this document without prior notice.



The terms HDMI™, HDMI™ High-Definition Multimedia Interface, HDMI™ Trade dress and the HDMI™ Logos are trademarks or registered trademarks of HDMI™ Licensing Administrator, Inc.

## Technical Support

If a problem arises with your system and no solution can be obtained from the user guide, please contact your place of purchase or local distributor. Alternatively, please try the following help resources for further guidance.

- Visit the MSI website for technical guide, BIOS updates, driver updates, and other information: <https://www.msi.com/support/>
- Register your product at: <http://register.msi.com>

## Revision History

- Version 1.0, 2024/11, First release.
- Version 1.1, 2025/04, Updated release.
- Version 1.2, 2025/05, Updated release.
- Version 1.3, 2026/02, Updated release.

